

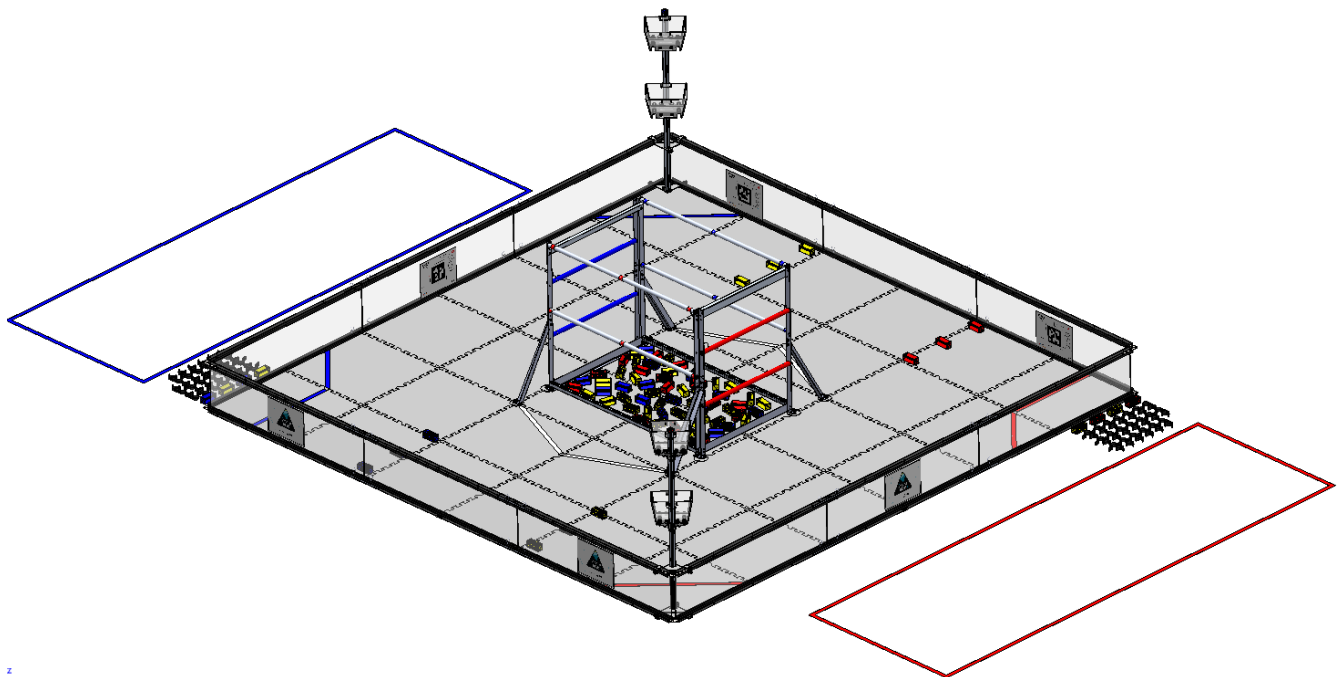

PRESENTED BY  RTX

2024-2025 *FIRST*[®] Tech Challenge Field Setup Guide



Revision #	Date	Author	Purpose
0	8/22/2024	E. Scime	Release
1	8/29/2024	E. Scime	Modified sample preset tape length
2	9/5/2024	E. Scime	Added warnings about handling metal parts
3	9/9/2024	E. Scime	Added additional deburring guidance



Table of Contents

Page #	Section
4	Recommended Tools
5	Basket Structure Parts List
7	Submersible Parts List
9	Scoring Elements List
10	Additional Materials List
12	Field & Perimeter Assembly
18	Submersible Assembly
29	Basket Structure Assembly
40	Tape Lines
47	Game-Specific Teardown



Recommended Tools List







Component	Part #	Quantity	Photo
Utility Knife	N/A	1	
Tape Measure	am-4986	1	
5/32 Hex Driver	am-2751	1	
3/8 Combination Wrench	am-4961	1	
3/8 Nut Driver	am-3877	1	
1/2 Combination Wrench	am-2746	1	
3/8" Impact Nutsetter	am-2755	1	
Drill	N/A	1	
Safety Gloves	N/A	1	
Flush Cutters	am-3910a	1	
(Optional) Deburring Tool or Sandpaper	N/A	1	



Basket Structure Parts List (am-5406)







Component	Part #	Quantity		Photo
		Full	Part	
Basket	am-3015	4	2	
Cable Tie, 11"	am-1631_natural	12	6	
Square Peanut Cap, Red	am-4305_red	2	1	
Square Peanut Cap, Blue	am-4305_blue	2	1	
Euroboard Upright, Red	am-5413_red	1	0 or 1	
Euroboard Upright, Blue	am-5413_blue	1	0 or 1	
44.5in Peanut	am-5412	2	1	
Basket Support Churro	am-2569	8	4	
Corner Mount Bracket	am-5410	4	2	



Component	Part #	Quantity		Photo
		Full	Part	
Basket Mount Clamp	am-5411	8	4	
Basket Mount Bracket	am-5414	4	2	
#10 Thumb Screw	am-4558	12	6	
Threadforming Screw, 1/4-20 0.75" Long	am-1310	8	4	
0.625" #10 Socket Head Cap Screw	am-1007	24	12	
#10 Nylock Nut	am-1042	24	12	



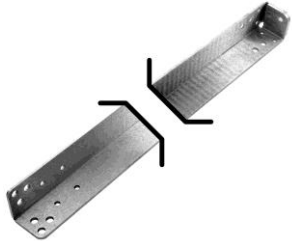

Submersible Parts List (am-5404)

Component	Part #	Quantity		Photo
		Full	Part	
Right Outrigger	am-5415	2	2	
Left Outrigger	am-5416	2	2	
Top Brace	am-5417	2	2	
Bottom Brace	am-5418	2	2	
Upright	am-5419	4	4	
Daisy Round Extrusion	am-5420	4	4	



Component	Part #	Quantity		Photo
		Full	Part	
44.5in Peanut	am-5412	2	2	
Threadforming Screw, 1/4-20 0.75" Long	am-1310	32	32	
26.5in Pipe, Red	am-5421_red	2	2	
26.5in Pipe, Blue	am-5421_blue	2	2	
Rubber Stopper	am-4806	8	8	
1/4" Washer	am-1027	8	8	
1/4-20 3.5" Hex Head Cap Screw	am-1605	8	8	
Under-tile Disk	am-5422	8	8	
3" Washer	am-1628	8	8	
1.25" Hex Head Bolt	am-1738	8	8	







Component	Part #	Quantity		Photo
		Full	Part	
¼-20 Wing Nut	am-1705	16	16	
#10 Nylock Nut	am-1042	32	32	
0.5" #10 Socket Head Cap Screw	am-1002	32	32	

Scoring Elements List

Component	Part #	Quantity		Photo
		Full	Part	
Neutral Sample	am-5401_yellow	40	20	
Red Sample	am-5401_red	20	10	
Blue Sample	am-5401_blue	20	10	
Clip	am-5402	40	20	



Additional Materials List (Not Included)

Component	Part #	Quantity	Photo
1" White Gaffers Tape	am-4951	1	
1" Red Gaffers Tape	am-4952	1	
1" Blue Gaffers Tape	am-4953	1	
Clear Plastic Sleeve, 8.5"x11"	N/A	6	
Color Printer	N/A	1	



FIELD & PERIMETER ASSEMBLY

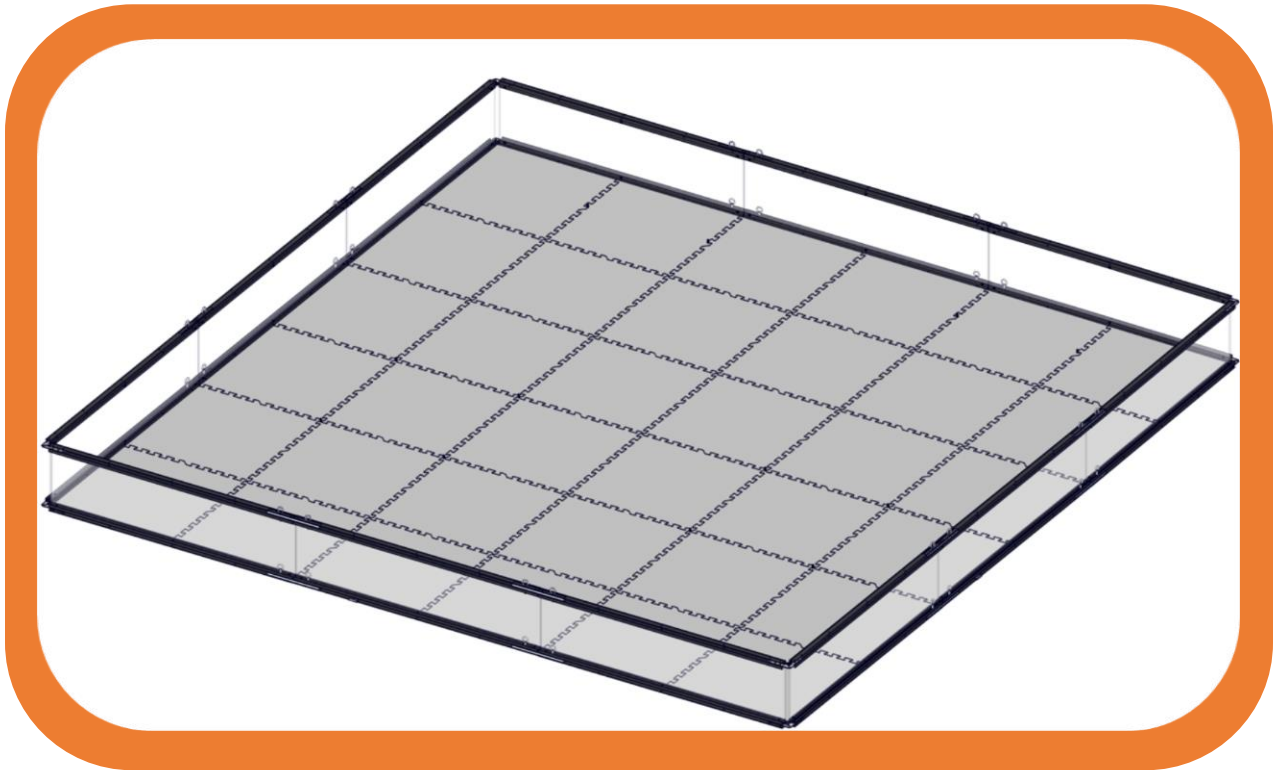

Field & Perimeter Assembly

Step 1

If using the AndyMark FTC Field Perimeter, follow the [FTC Field Perimeter Setup Guide](#) to construct your field border. Scan or tap this QR code to view.



If using a different border, follow its associated assembly guide. Note that different borders will have varying heights, as listed in the table below.

Perimeter	Wall Design Categories	Wall Height
AndyMark (current)	Smooth on one side and an open cavity on the other side	12.125"
IFI Perimeter	Smooth on one side and an open cavity on the other side	11.5"

Step 2

Remove material from one edge of 16 soft tiles until that edge is flat. For 4 additional tiles, do this on two adjacent edges, making the corners of the field.

NOTE: It is possible you may receive soft tiles that are smaller in size than expected. You may want to place your tiles in your perimeter (Step 3) before cutting off the edges (Step 2) to ensure you completely fill the perimeter by cutting less from each edge.

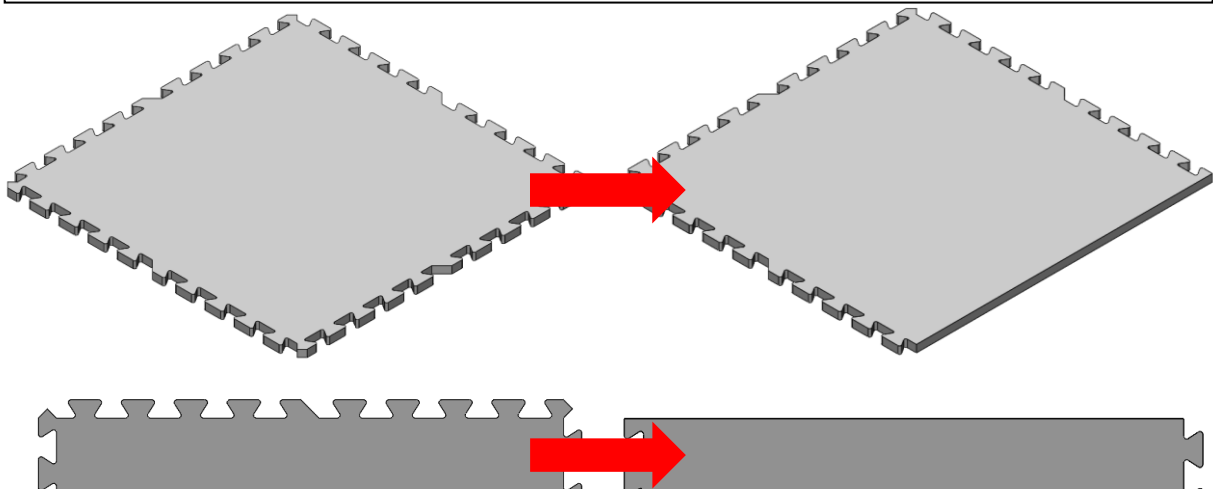

Step 3

Place the straps centered on the field walls as shown. Use the cut tiles (16 with a single edge cut, 4 with two adjacent edges cut) to form the outer edge of the field floor inside the Field Border. Fill in the rest of the floor with uncut tiles. In total there should be 36 tiles placed.

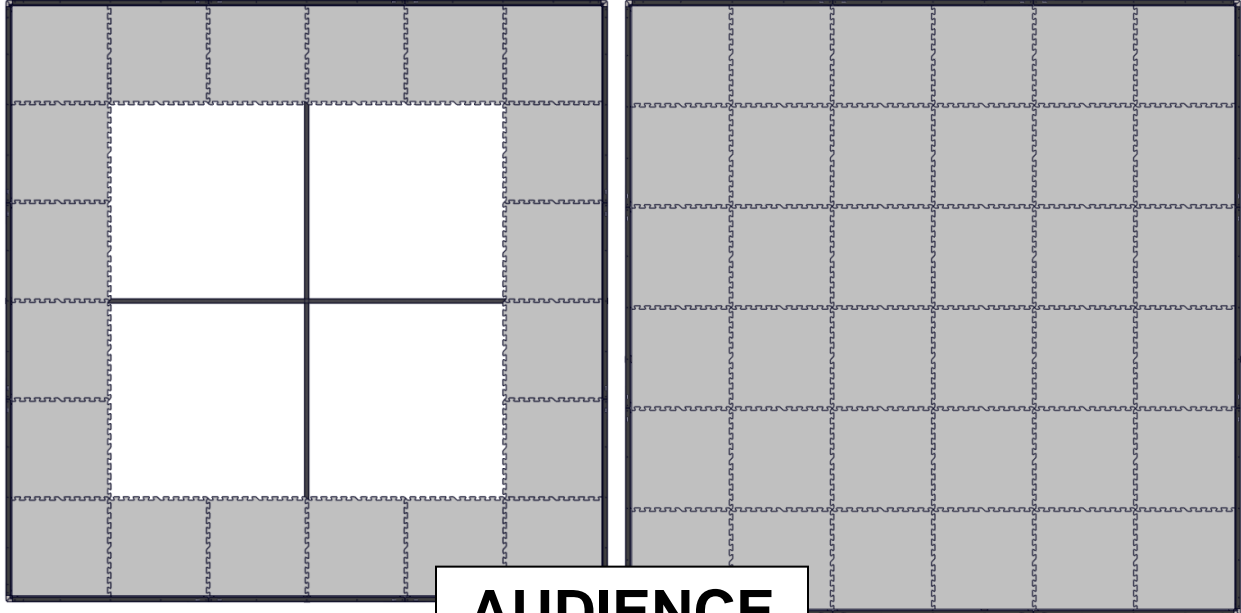

Step 4

Prepare the Undertile Disk Assemblies by inserting (1) Hex Head Bolt (am-1738) through the hole in the Undertile Disks (am-5422). Ensure the head of the screw completely recesses into the disk. Prepare 8 of these assemblies.

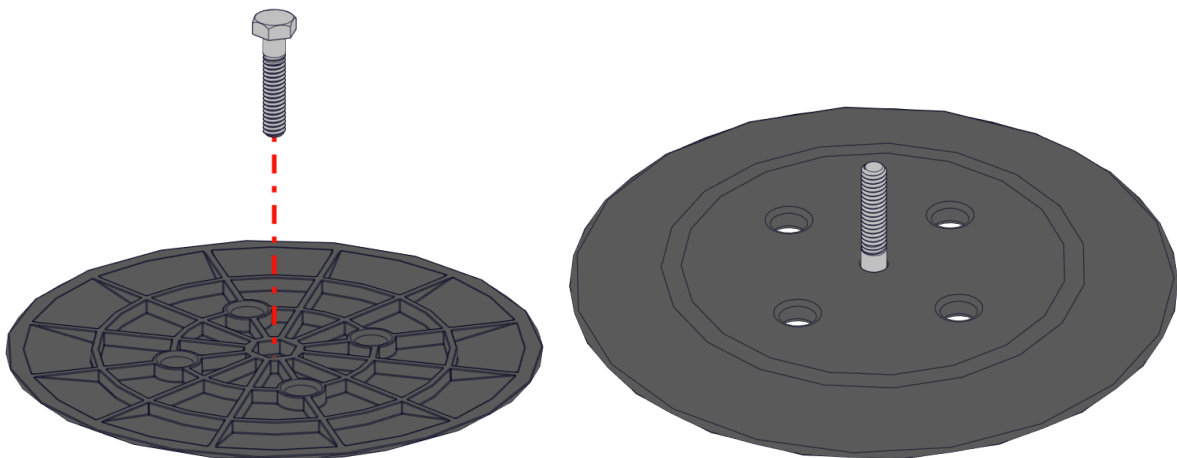

8X



Step 5

Slip the Undertile Disk assemblies underneath the tiles at the locations shown.

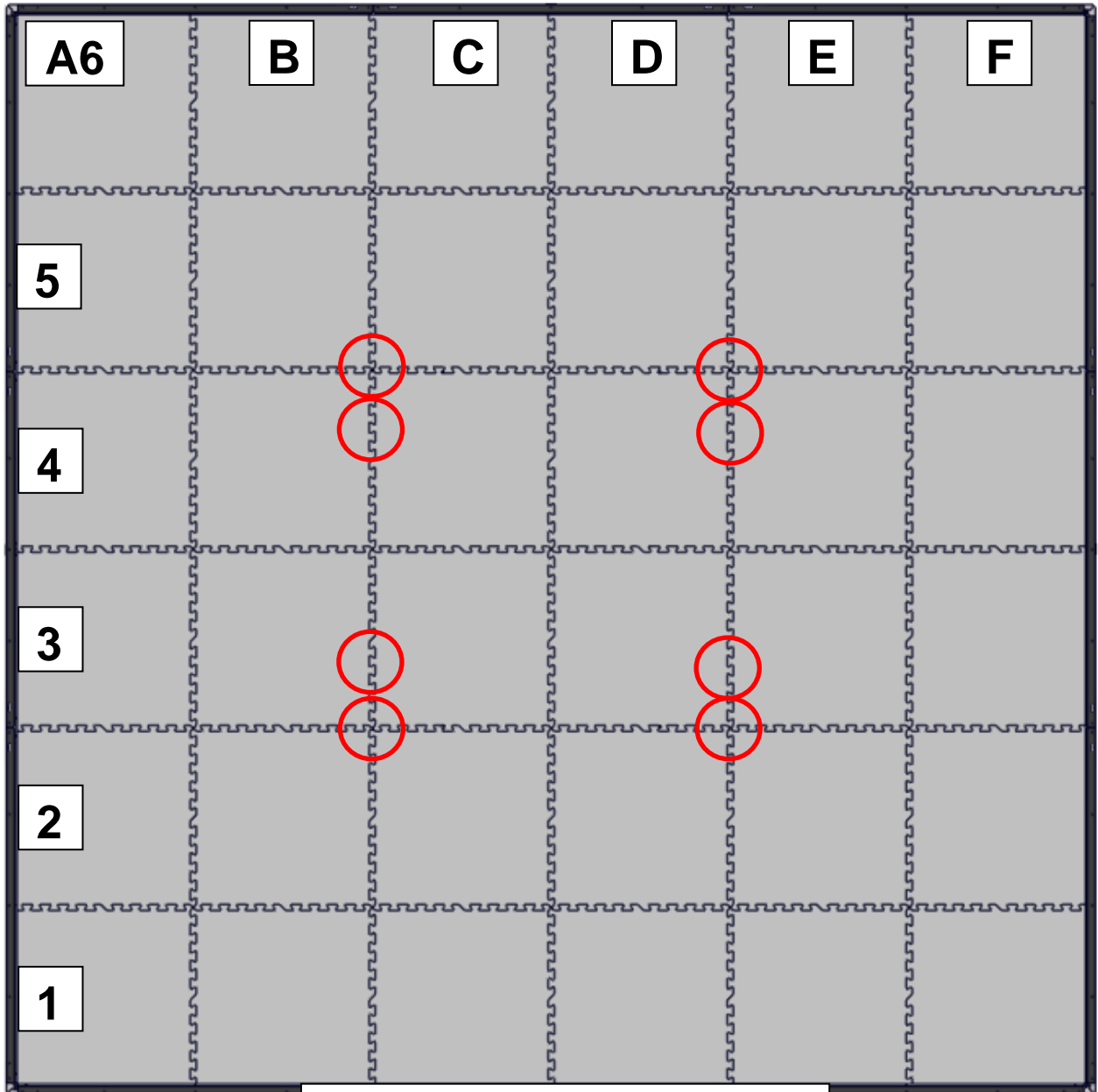
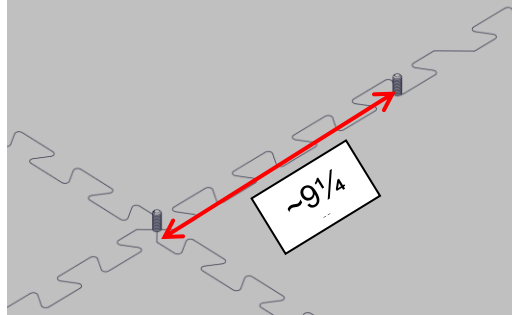

AUDIENCE



The screws that are **not** at 4-tile junctions are biased towards the center of the field as shown.

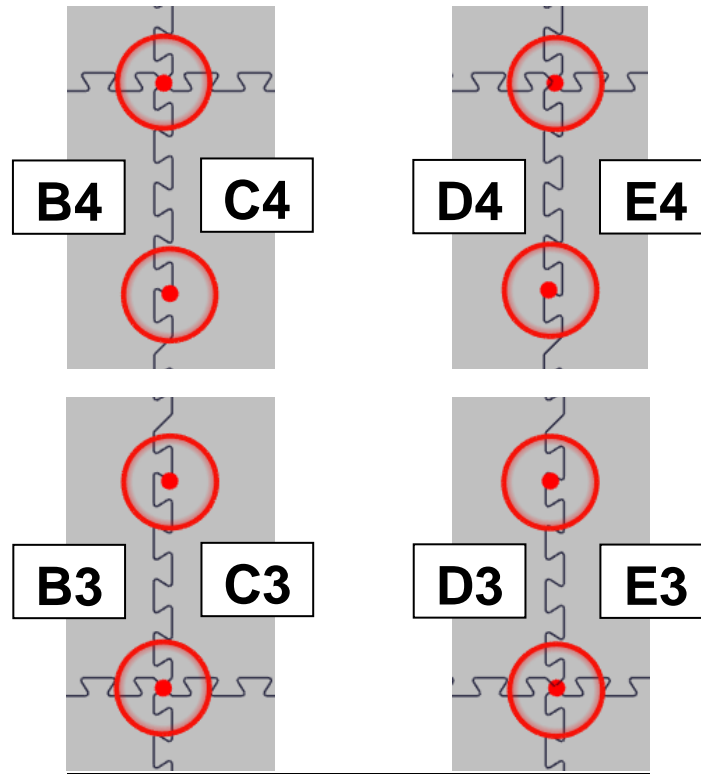

Step 6

Add 4 white tape lines to mark the ASCENT ZONE. The exterior edge of the diagonal tape is 10" away from the root of the tile seams between Rows 2 & 3 and Rows 4 & 5, and in line with the center column seam, as shown. The other end of the tape is placed such that it is to the furthest corner of the tile but fully contained to one tile, as shown.

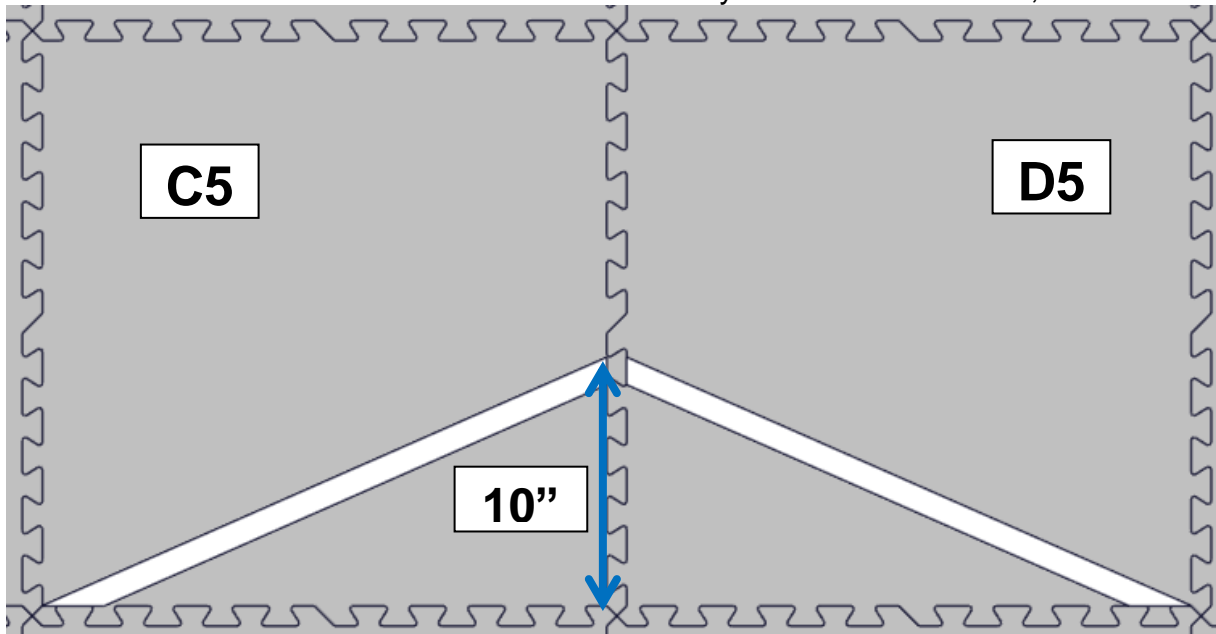

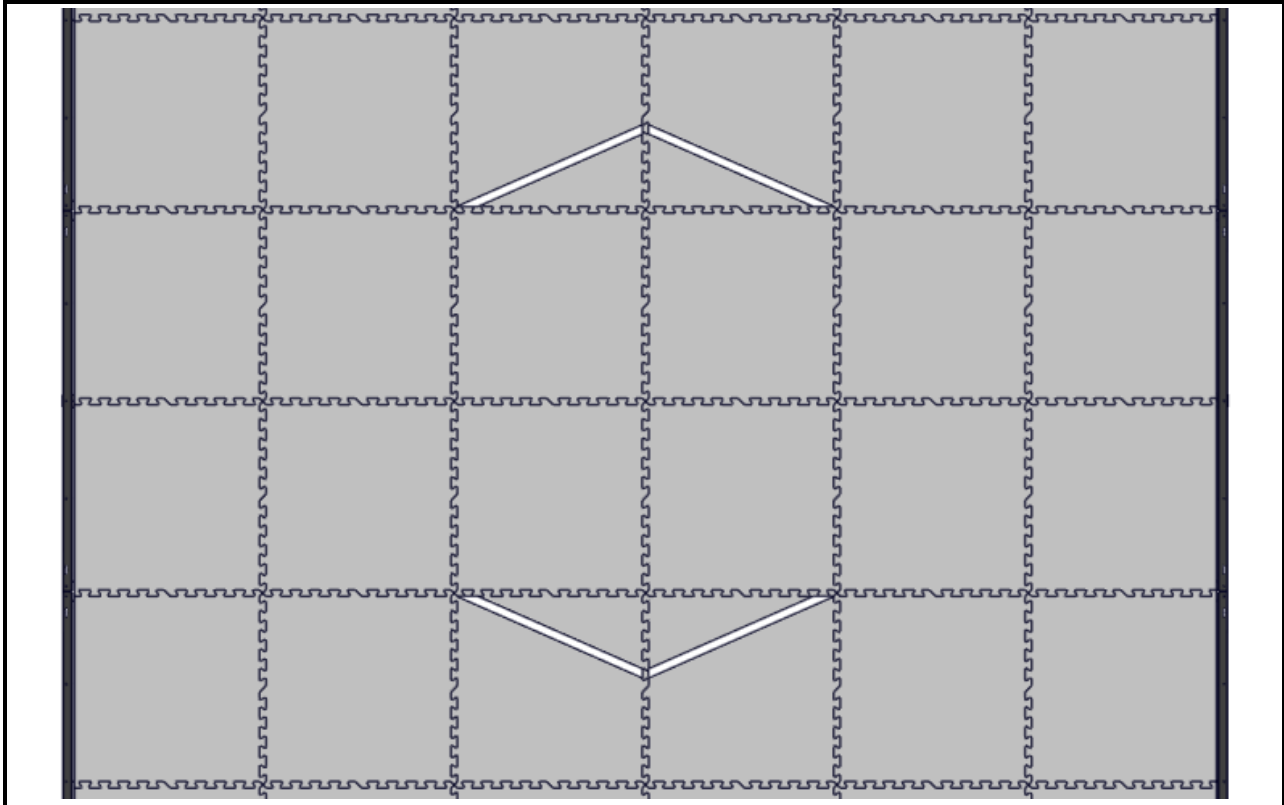

Step 7

Slide 3" Fender Washers (am-1628) over the Bolts sticking up through the tiles that were placed during Step 5.

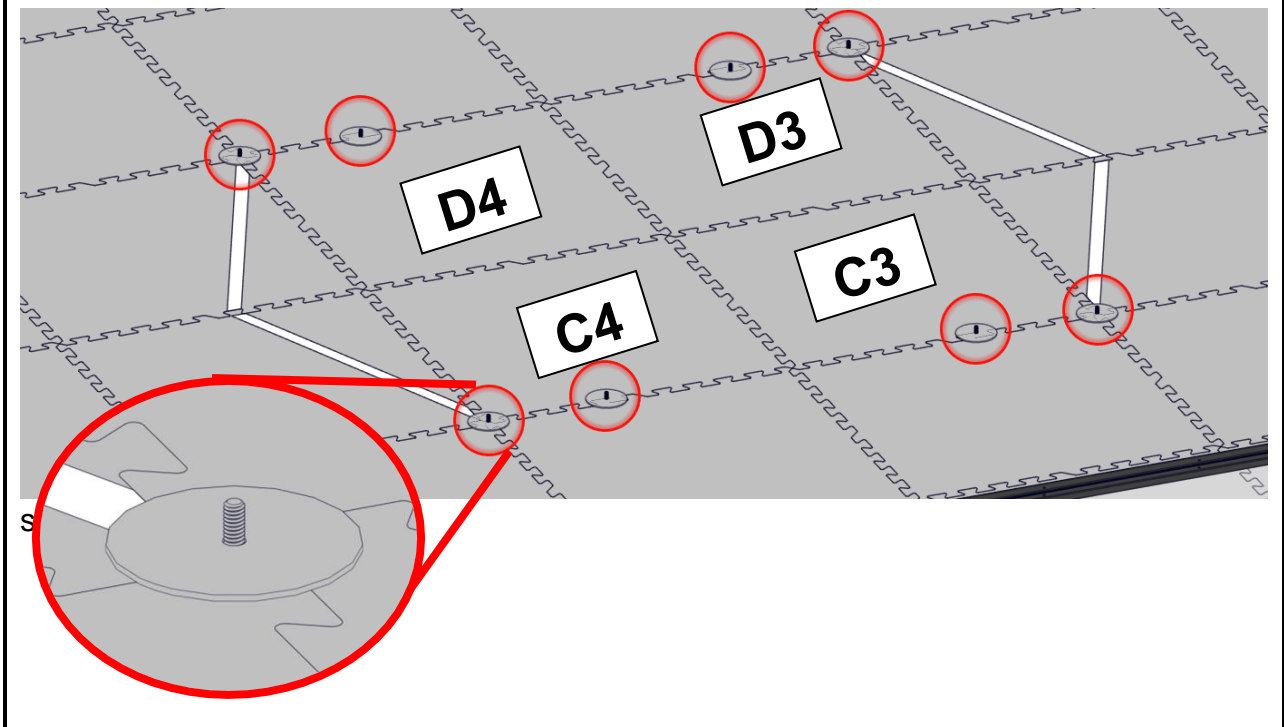

SUBMERSIBLE ASSEMBLY

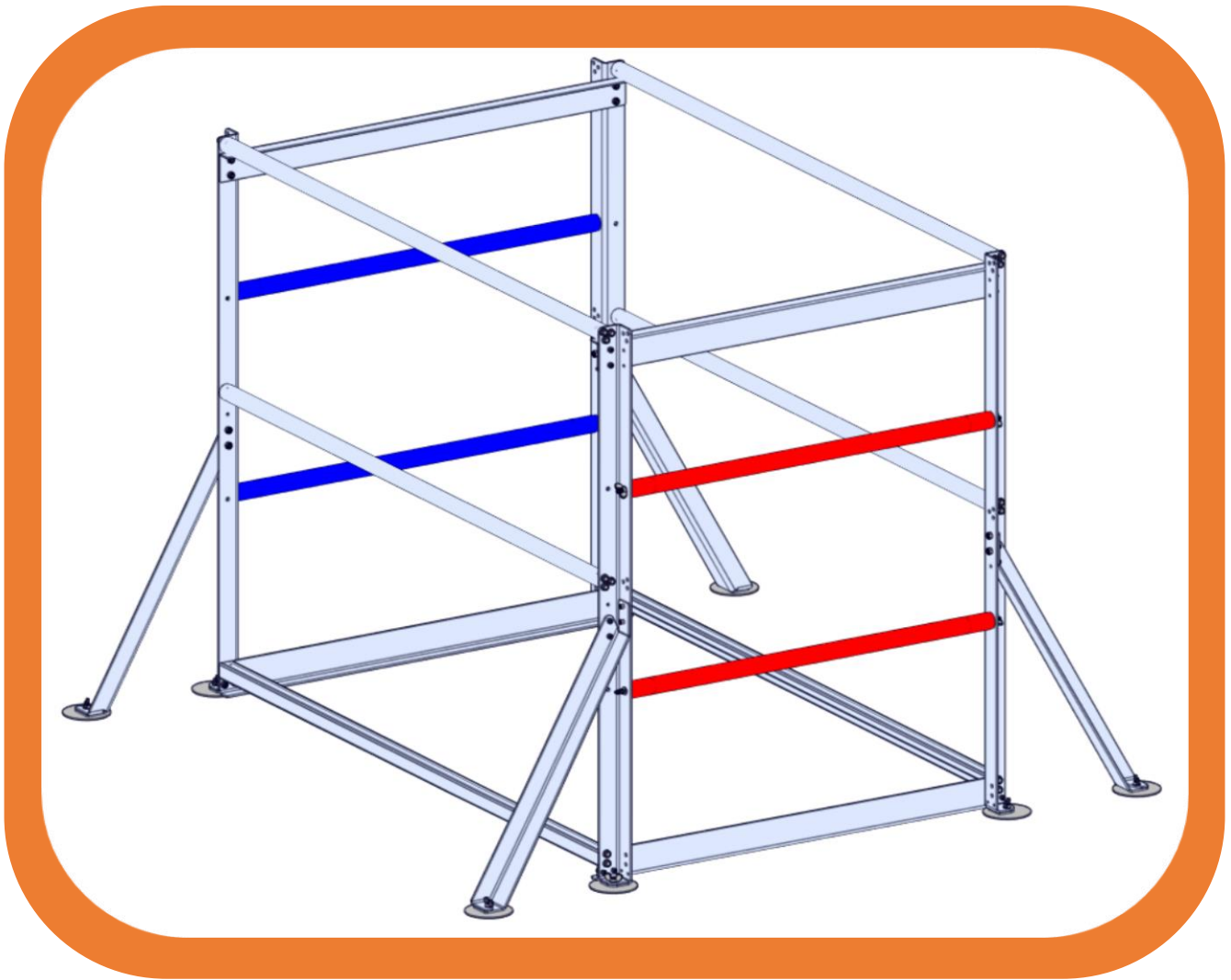



WARNING

Metal parts **MAY** have sharp edges. Be careful when handling them. Using gloves is recommended. Sharp edges can be deburred with a deburring tool or sandpaper.



Submersible Assembly

Step 1

Attach two pieces of Daisy Round Extrusion (am-5420) between two Sheet Metal Uprights (am-5419) using (3) Threadforming Screws (am-1310) per junction (12 total) as shown below.

There may be sharp burrs present at these locations on the Uprights. It is required to deburr them all using a file or sandpaper.

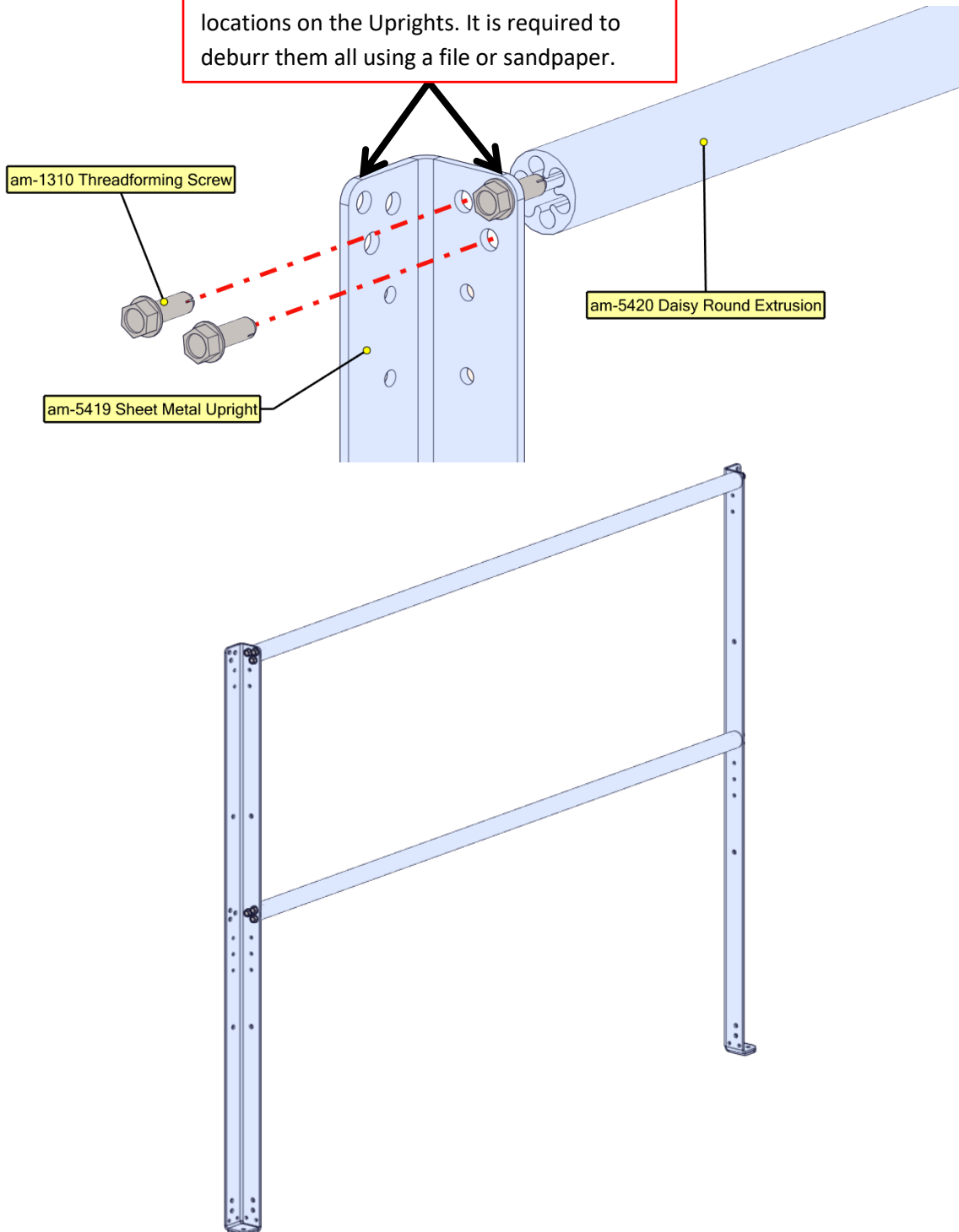

Step 2

Attach one piece of 44.5in Peanut Extrusion (am-5412) to the frame created in Step 1 with (4) Threadforming Screws (am-1310). These frames should not be disassembled in the future and should be transported in this configuration to avoid cycling the Threadforming Screws.

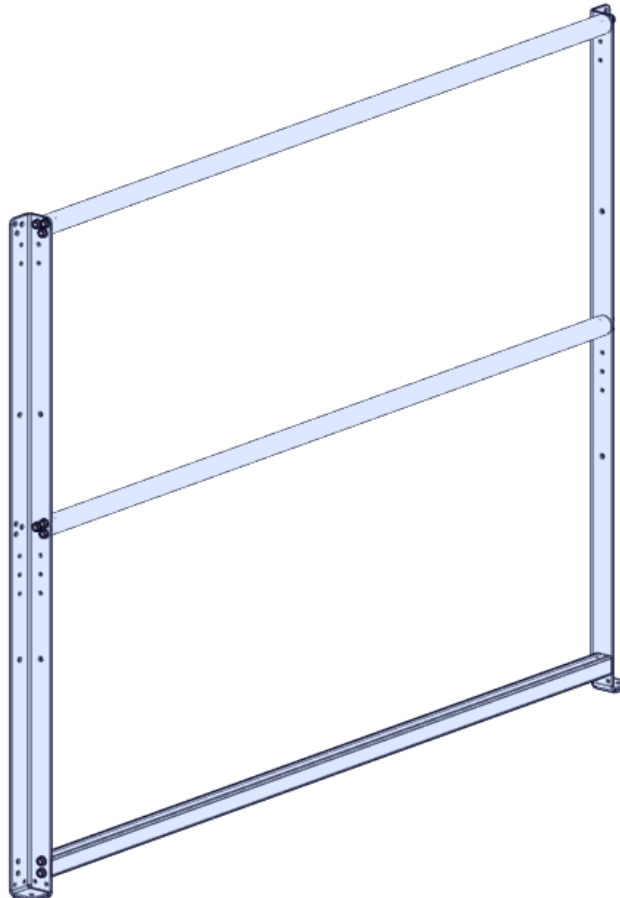
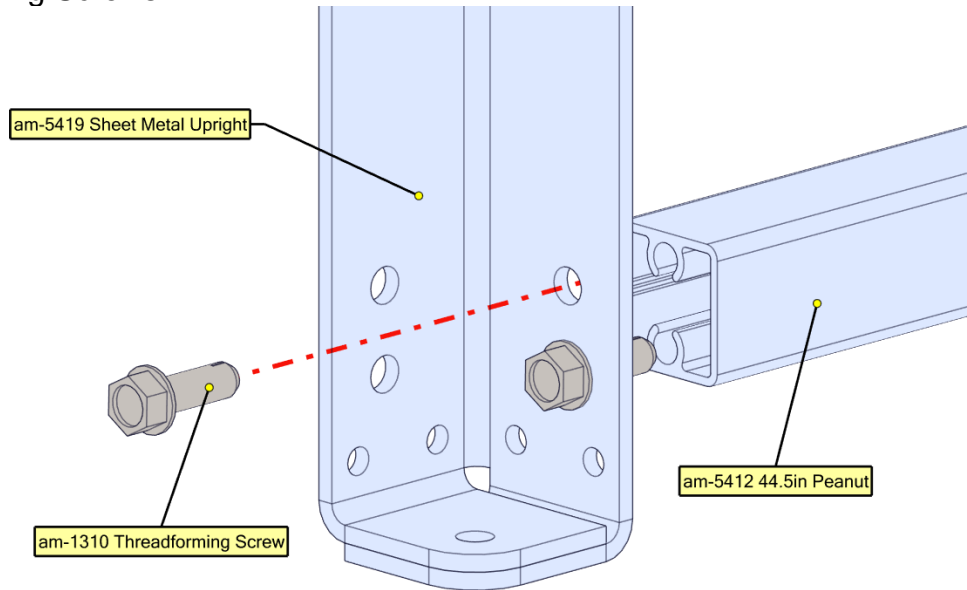

Step 3

Attach (1) am-5416 Left Sheet Metal Outrigger to the frame and (1) am-5415 Right Sheet Metal Outrigger to the frame using (8) 0.5in 10-32 Socket Head Cap Screws (am-1002) and (8) 10-32 Nylock Nuts (am-1042).

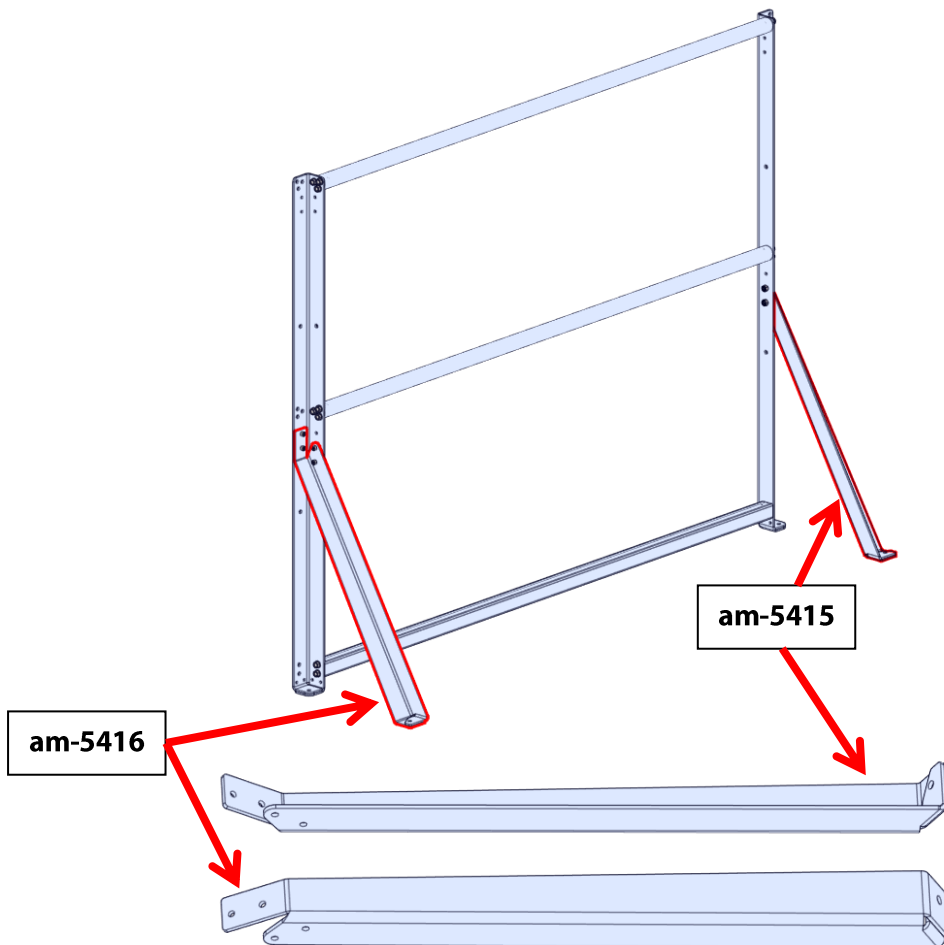
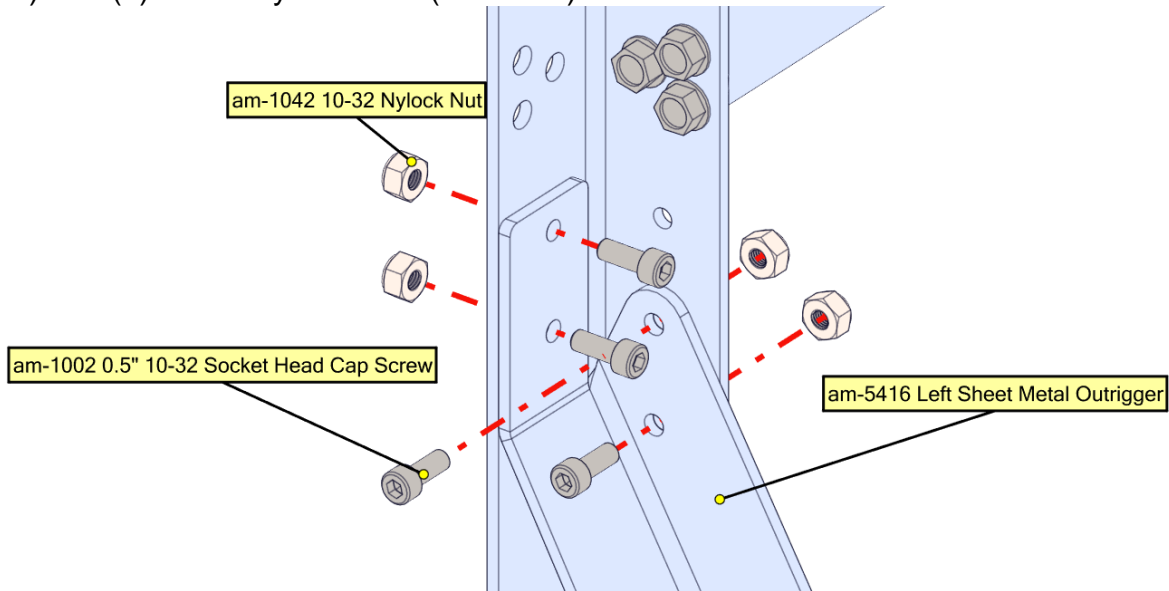

Step 4

Repeat Steps 1-3 to create a second frame, identical to the first.

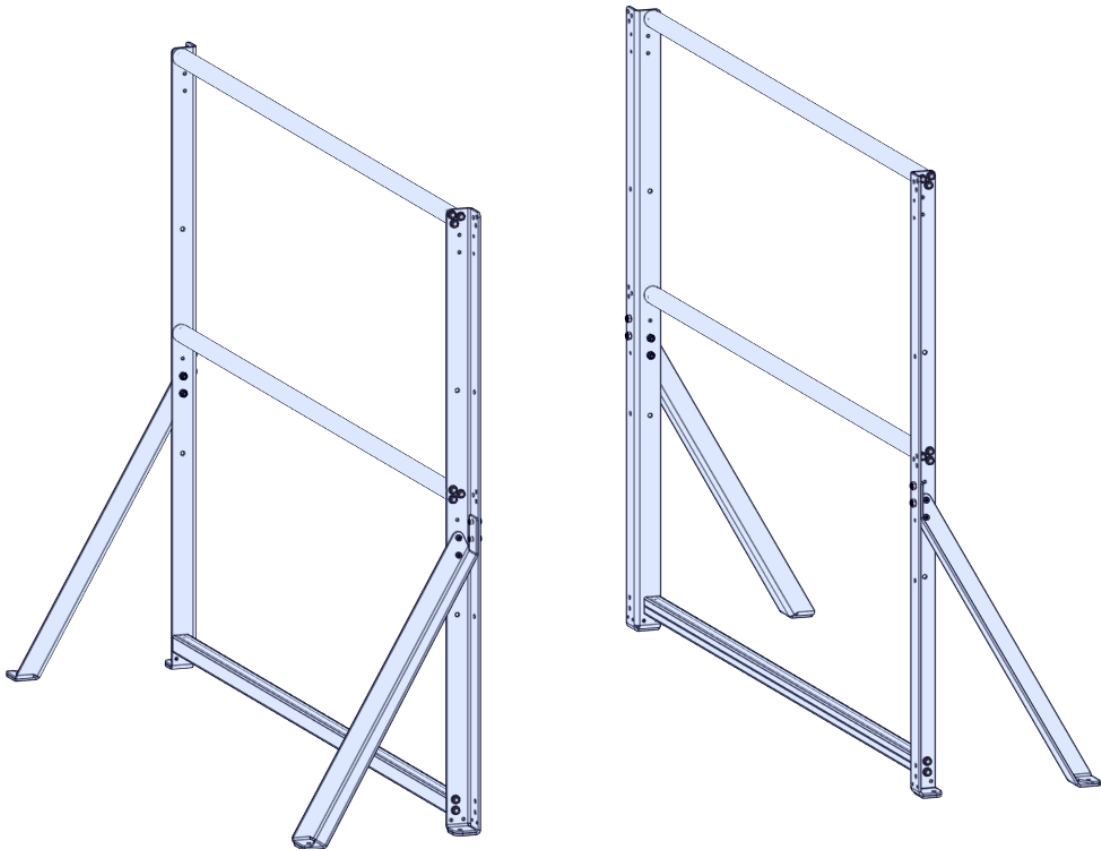

Step 5

Insert 3.5" long 1/4-20 hex head screws (am-1605) through 1/4" washers (am-1027) and rubber stoppers (am-4806). Push the small end of the rubber stopper completely into a Red Pipe (am-5421_red) **OR** Blue Pipe (am-5421_blue) using a ball end driver or similar tool. Press around the edges of the rubber stopper to ensure that it is inserted straight and the screw exits parallel to the pole. Do this on both ends of the pipe. Create 2 assemblies for each color of pipe.

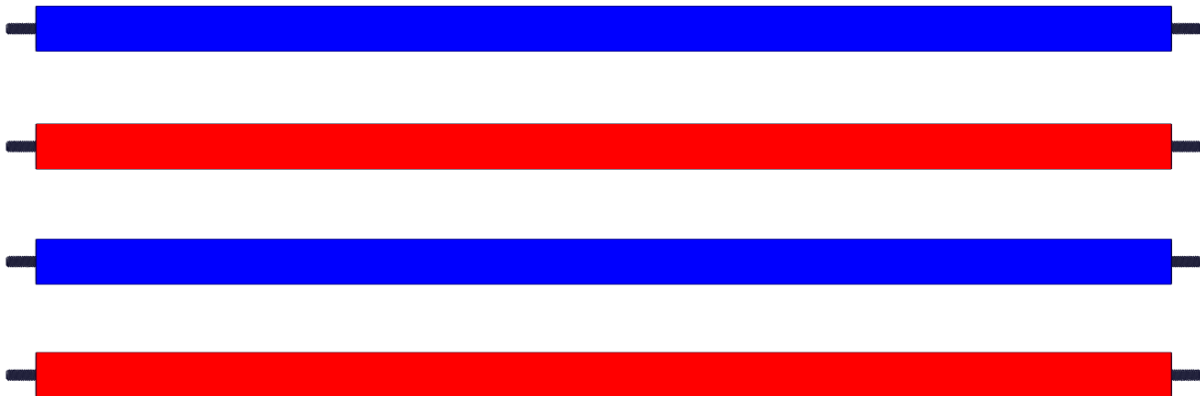
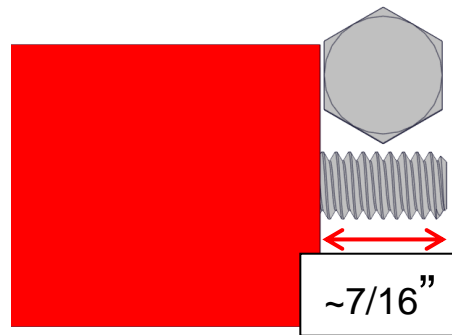
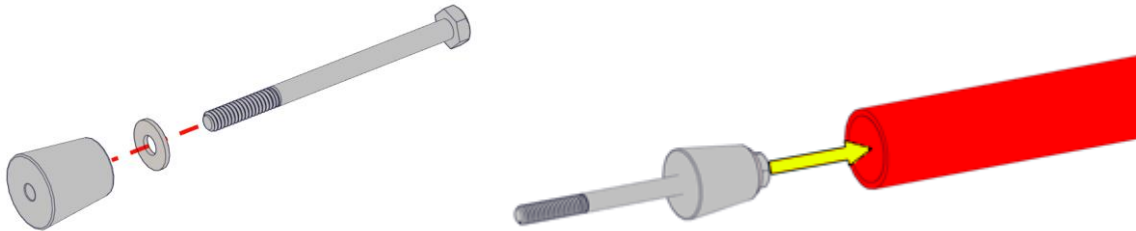

Step 6

Attach the assemblies you created in Step 5 to the Submersible frames using (2) Wing Nuts (am-1705) per assembly and (8) Wing Nuts total. Tighten until the pipe is flat against the upright.

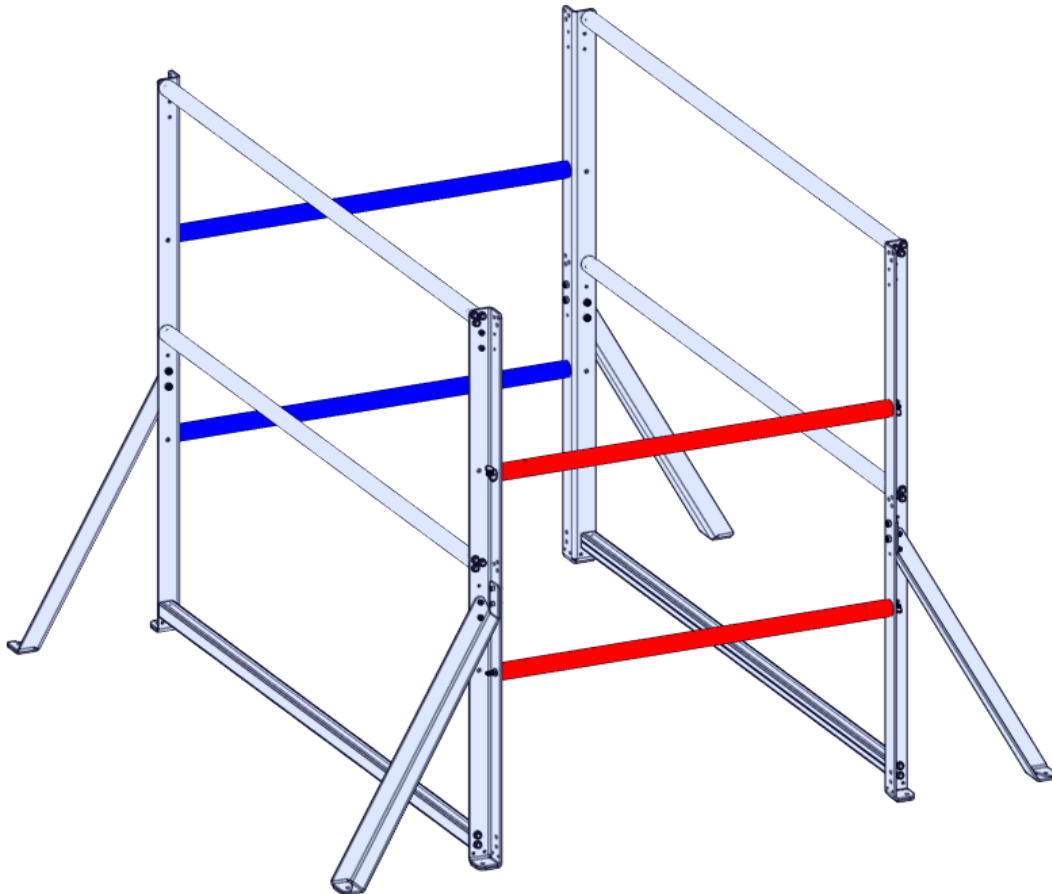
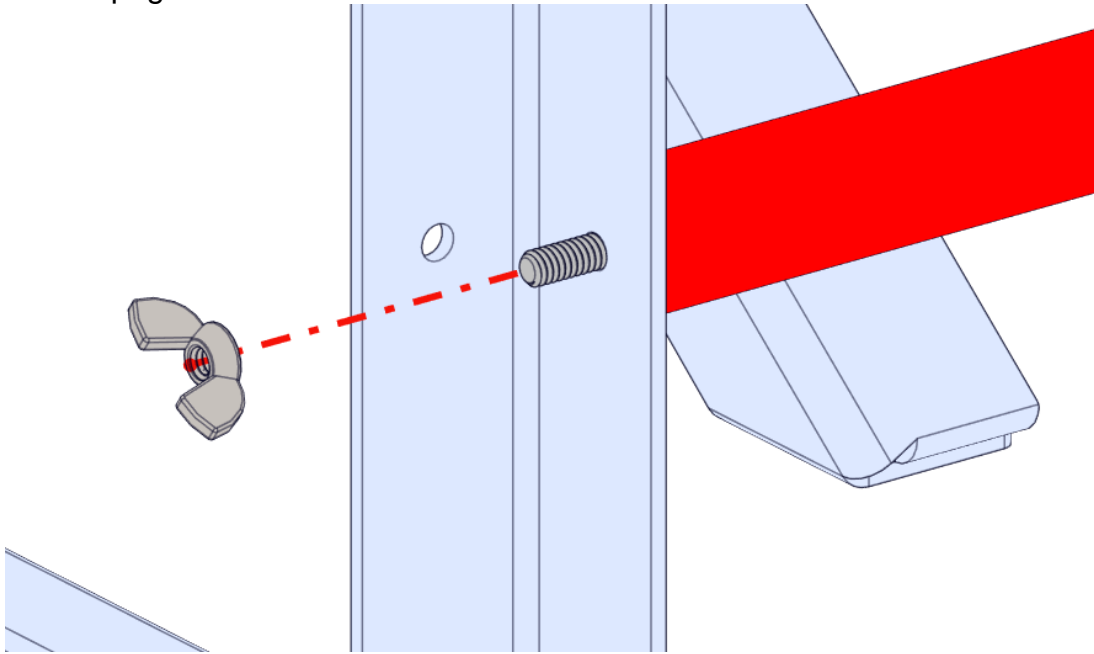

Step 7

Attach the two frames from Step 4 together at the bottom using (2) Bottom Braces (am-5418), (8) 0.5in 10-32 Socket Head Cap Screws (am-1002), and (8) 10-32 Nylock Nuts (am-1042).

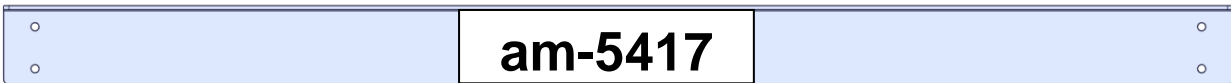
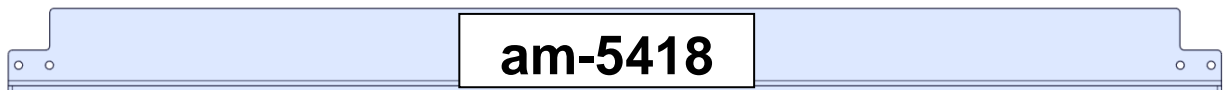
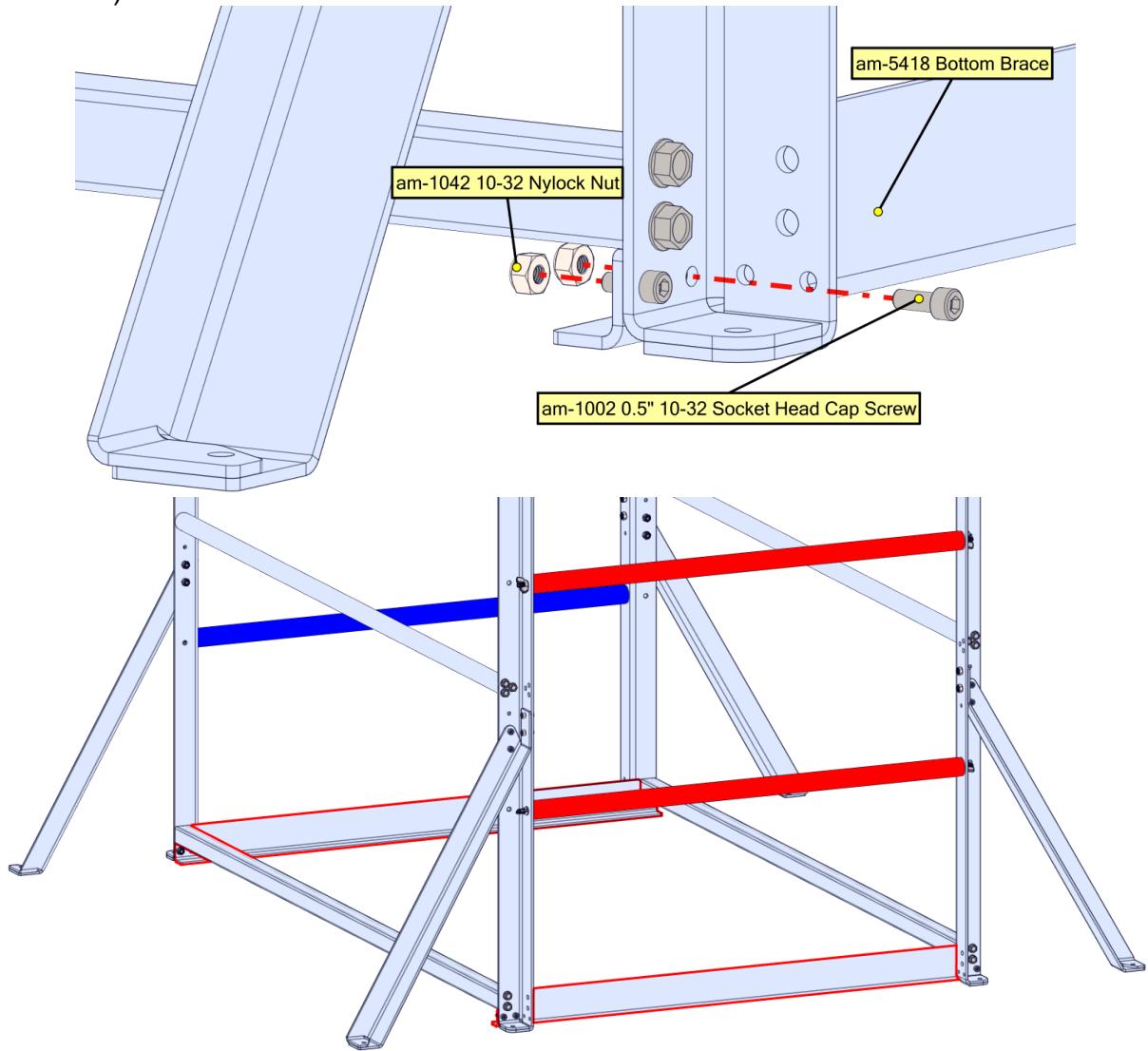

Step 8

Connect the top of the assembly together at the top using (2) Top Braces (am-5417), (8) 0.5in 10-32 Socket Head Cap Screws (am-1002), and (8) 10-32 Nylock Nuts (am-1042).

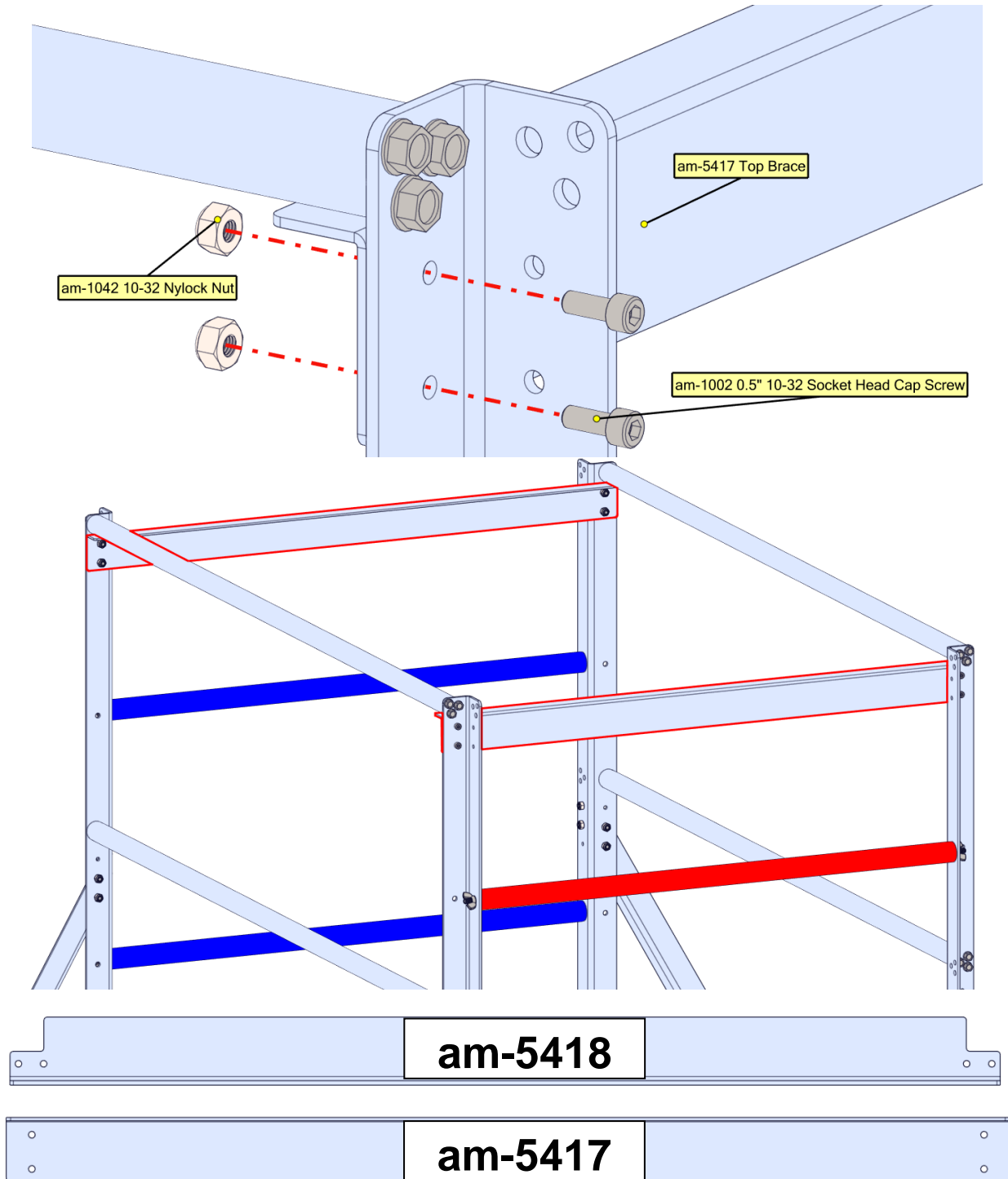

Step 9

Place the Submersible Assembly down on the floor, lining up each of its legs with the Hex Head Bolts sticking up through the tiles. Affix the Submersible to the bolts using (8) Wing Nuts (am-1705). The Submersible is now complete.

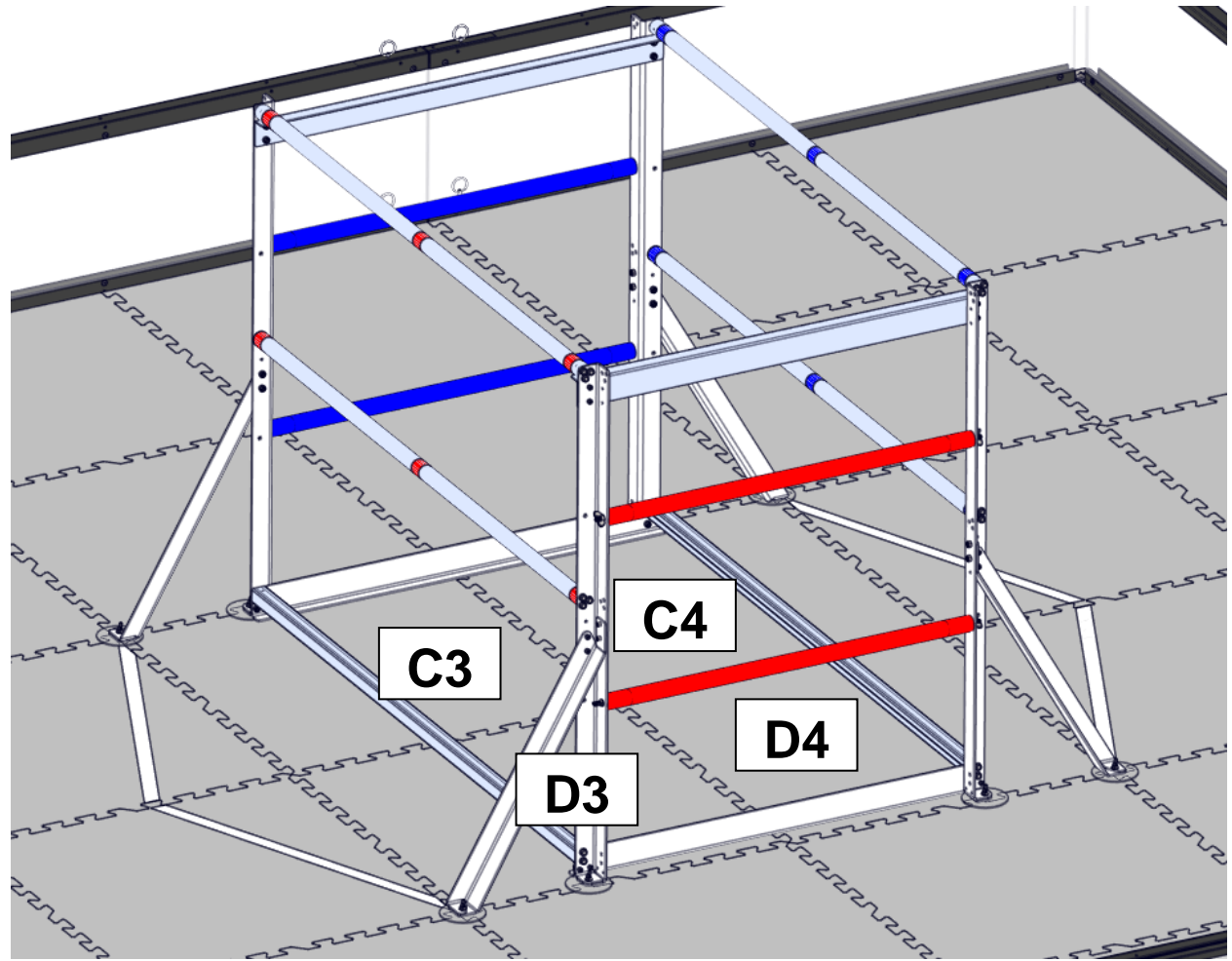
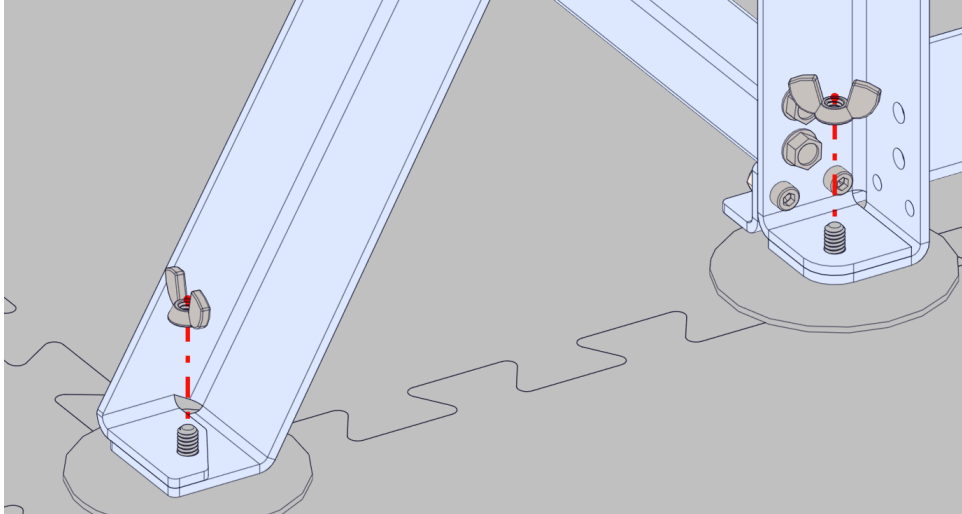

BASKET STRUCTURE ASSEMBLY

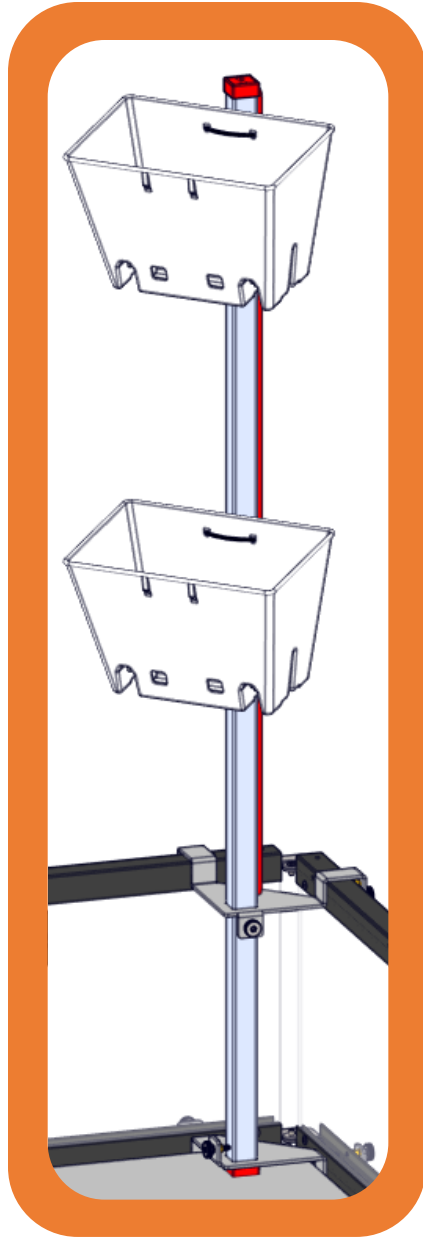



WARNING

Metal parts MAY have sharp edges. Be careful when handling them. Using gloves is recommended. Sharp edges can be deburred with a deburring tool or sandpaper.



Basket Structure Assembly

Step 1

Place a Corner Mount Bracket (am-5410) on both the top and bottom of the field perimeter above Tile A6 or Tile F1. Loosely screw (4) #10 Thumb Screws (am-4558) into the brackets as shown. See the diagram on the next page for which hole to place the Thumb Screws in based on your perimeter.

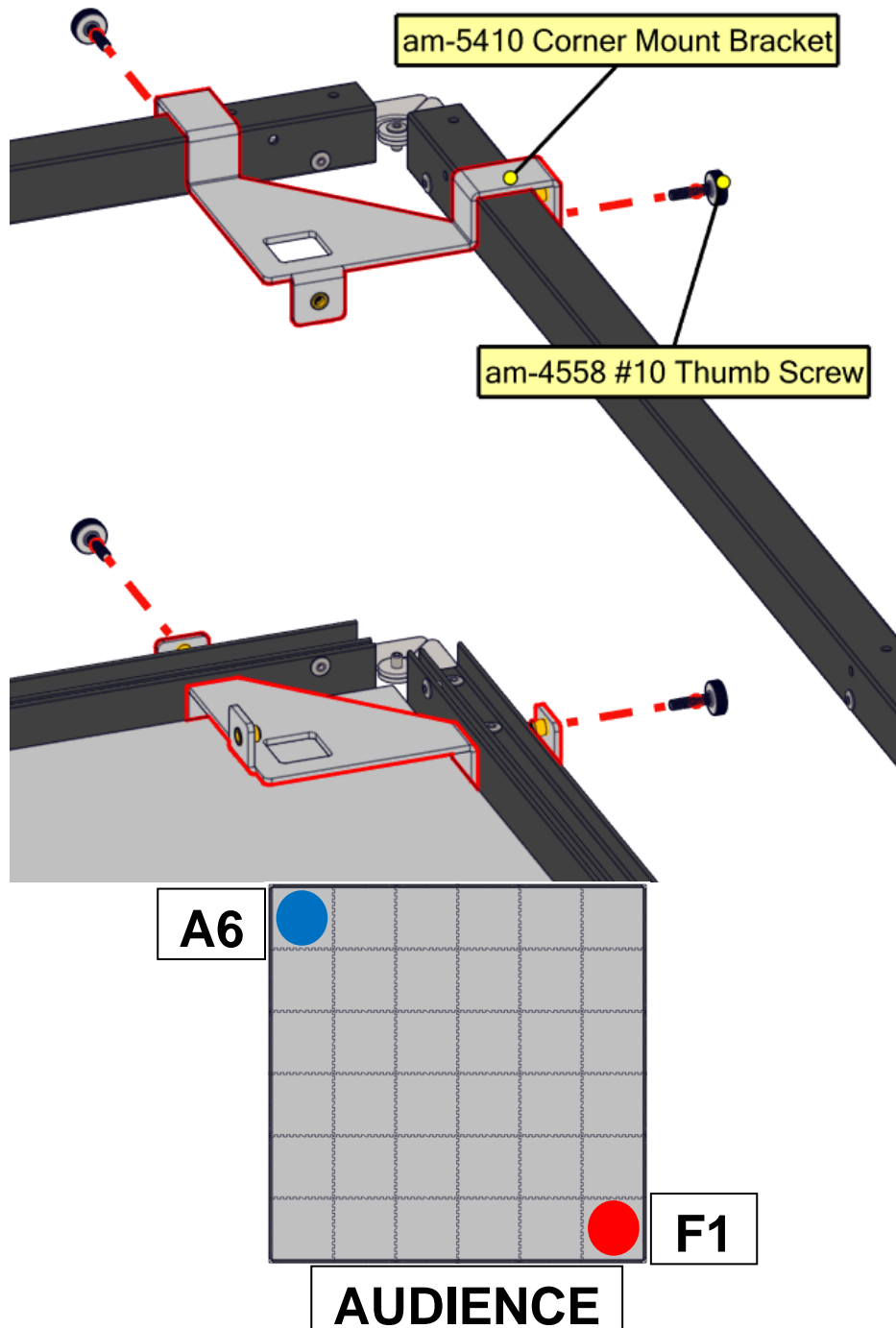

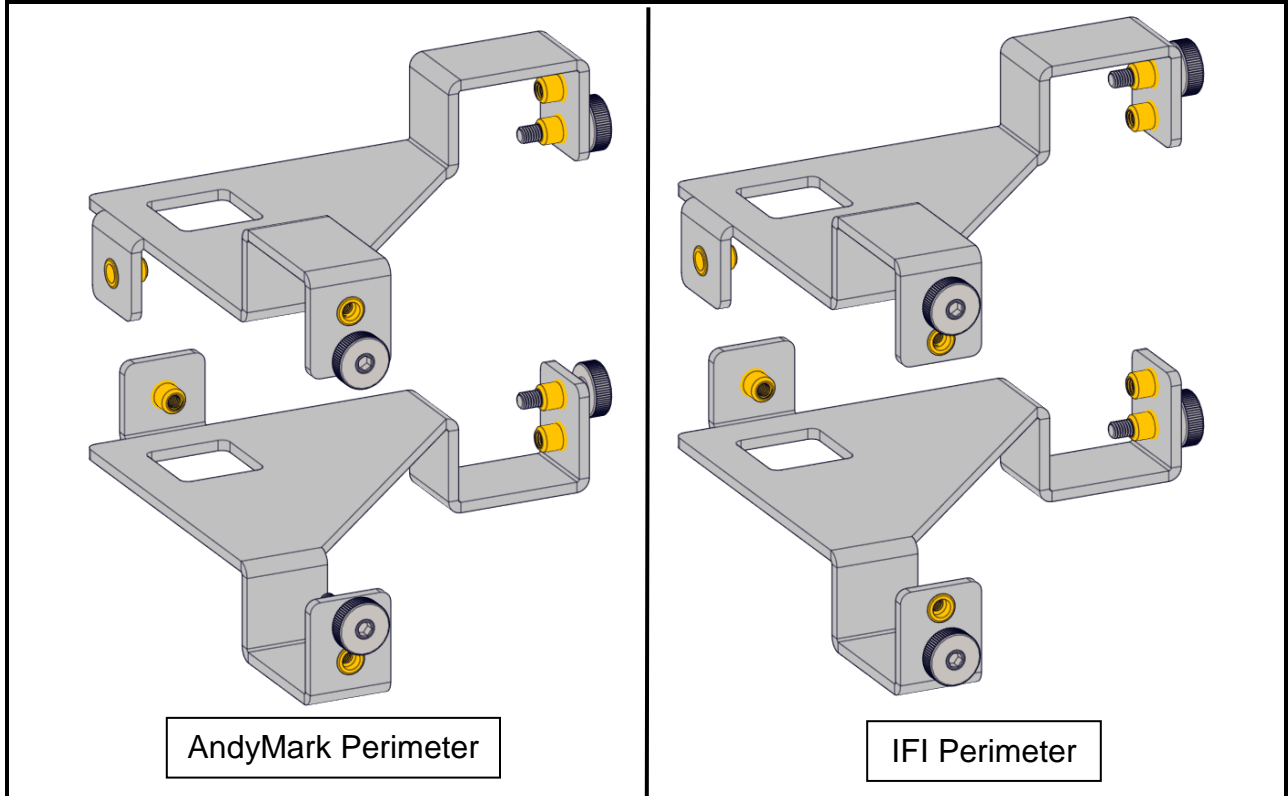

Step 2

Underneath the lower Corner Mount Bracket (am-5410), place (1) Square Peanut Cap (am-4305_red if building over Tile F1, am-4305_blue if building over Tile A6). Insert (1) 44.5in Peanut (am-5412) into the Square Peanut Cap, passing through each of the Corner Mount Brackets.

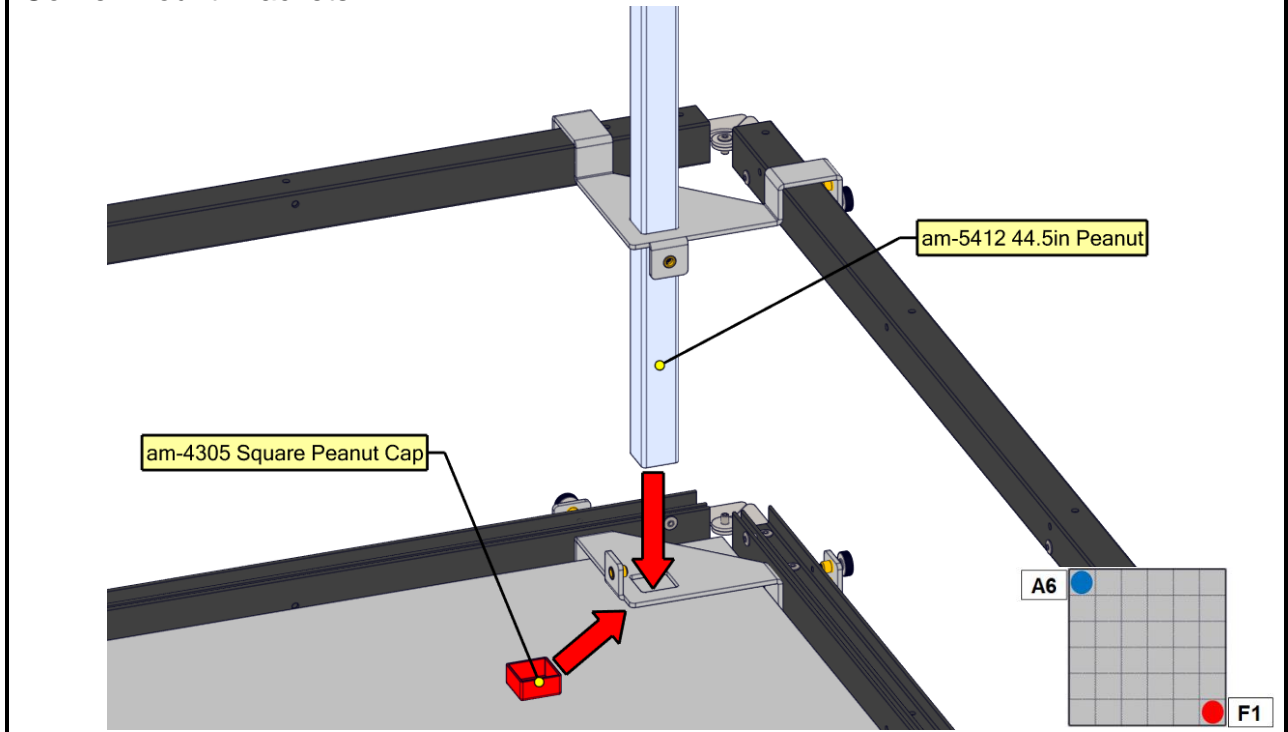

Step 3

Screw in (2) more #10 Thumb Screws (am-4558) into the Corner Mount Brackets (am-5410). Tighten all six Thumb Screws to secure the entire assembly.

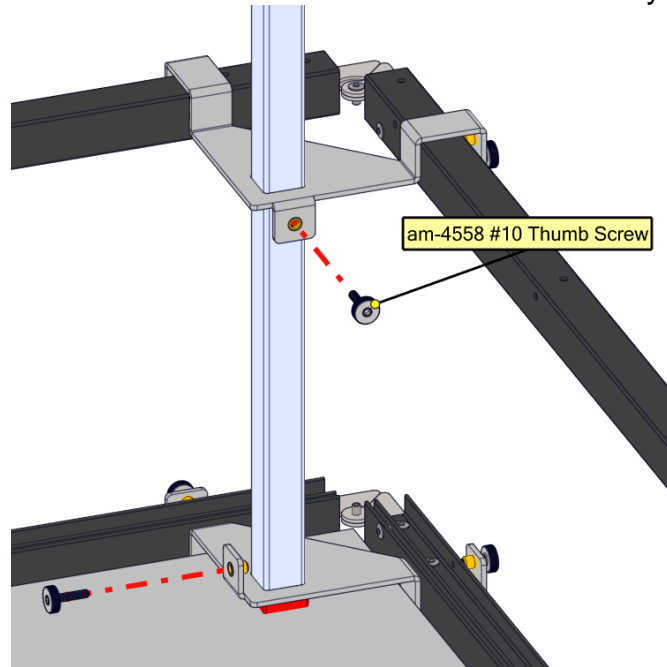

Step 4

Attach (1) Basket Mount Bracket (am-5414) to (1) Basket Mount Clamp (am-5411) using (2) 0.625in long 10-32 Socket Head Cap Screws (am-1007) and (2) 10-32 Nylock Nuts (am-1042). **Leave the assembly very loose.** The nuts should not be tightened beyond what is required to attach them to the screw.

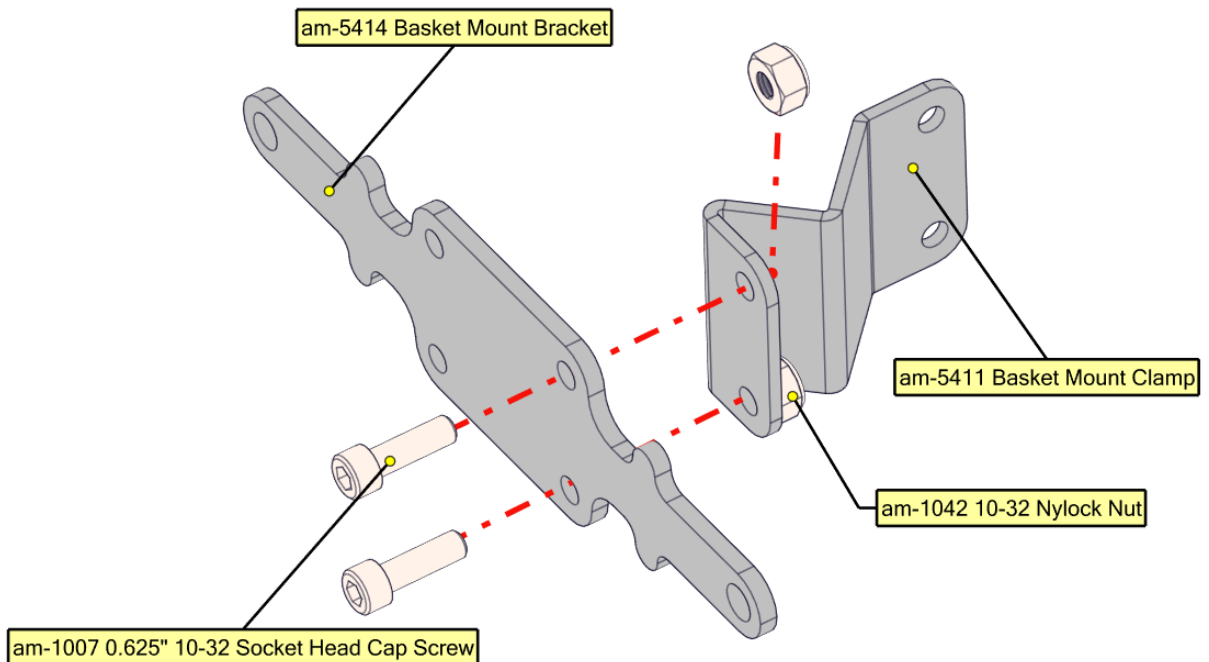

Step 5

Attach a second Basket Mount Clamp (am-5411) to the assembly created in Step 4 in the same manner. **Leave the assembly very loose.**

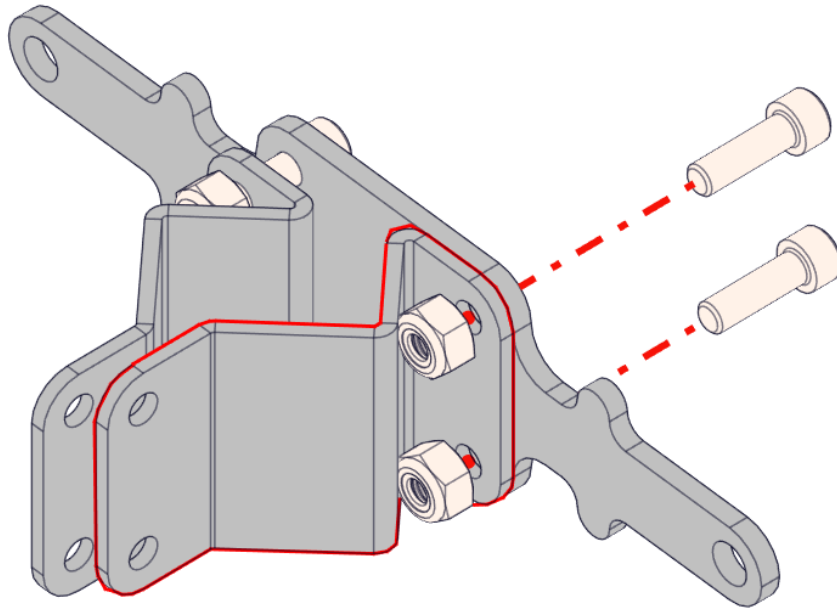

Step 6

Attach (2) 3.375" Churros (am-2569) to the assembly created in Step 5 with (2) Threadforming Screws (am-1310). Use a 1/2in wrench to hold the churro in place and a 3/8in wrench or socket driver to spin the screws. These screws should be fully tightened. These screws are thread forming and will have an abnormally high resistance when tightening.

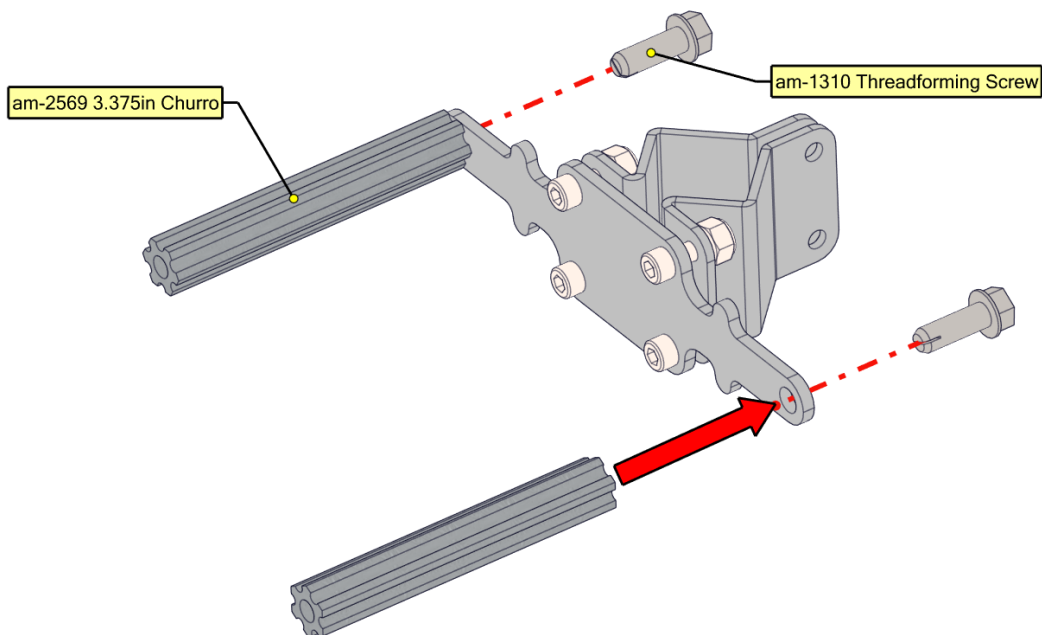

Step 7

Repeat Steps 4 through 6 to prepare a second Basket Mounting Assembly.

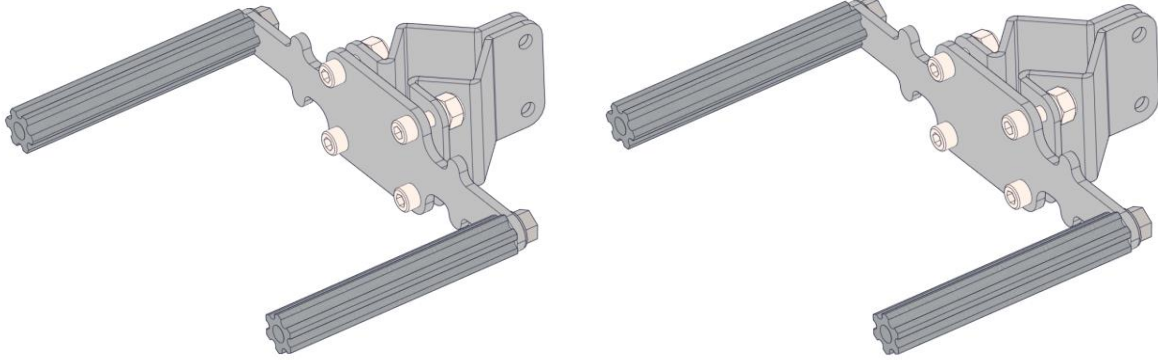

Step 8

Attach (1) of the assemblies from Step 7 to the Basket Structure by slipping it over the 44.5in Peanut (am-5412), sliding in the Euroboard Upright (am-5413_red if above Tile F1, am-5413_blue if above Tile A6), and bolting it in place with (2) 0.625in long 10-32 Socket Head Cap Screws (am-1007) and (2) 10-32 Nylock Nuts (am-1042). Tighten all (6) screws at this time. **The rounded end of the Euroboard should be at the top.**

- If building with an AndyMark perimeter, sliding the Euroboard all the way to the Corner Mount Bracket (am-5410) will set all heights properly. Measure and adjust the height of the Euroboard to 10-7/8in from the top of the tile to ensure variations in the field do not affect the Basket heights.
- If building with an IFI perimeter, make sure to measure 10-7/8in up from the top of the tile to the bottom of the Euroboard.

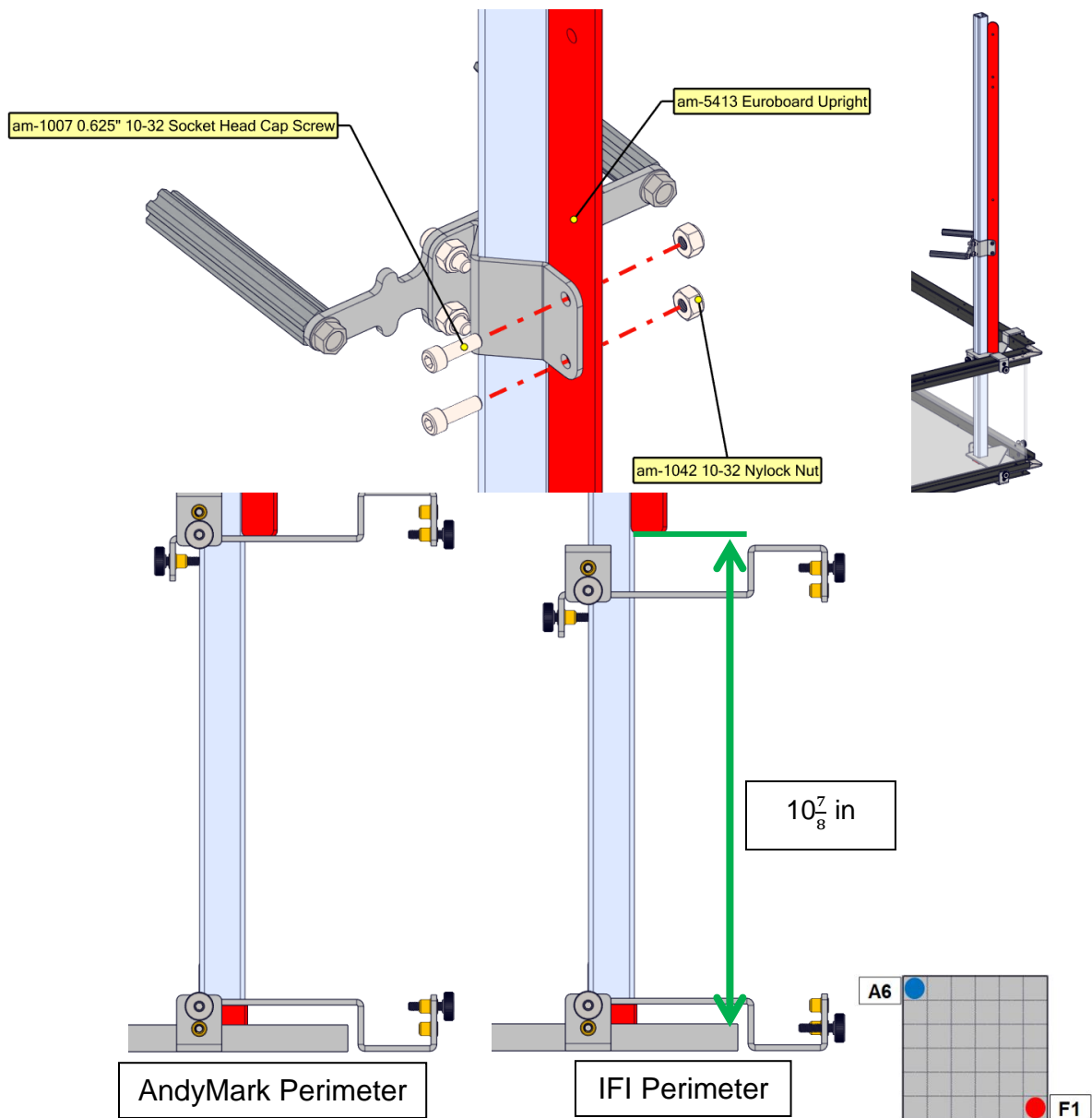

Step 9

Attach the second assembly above the first, in the same manner as in Step 8.

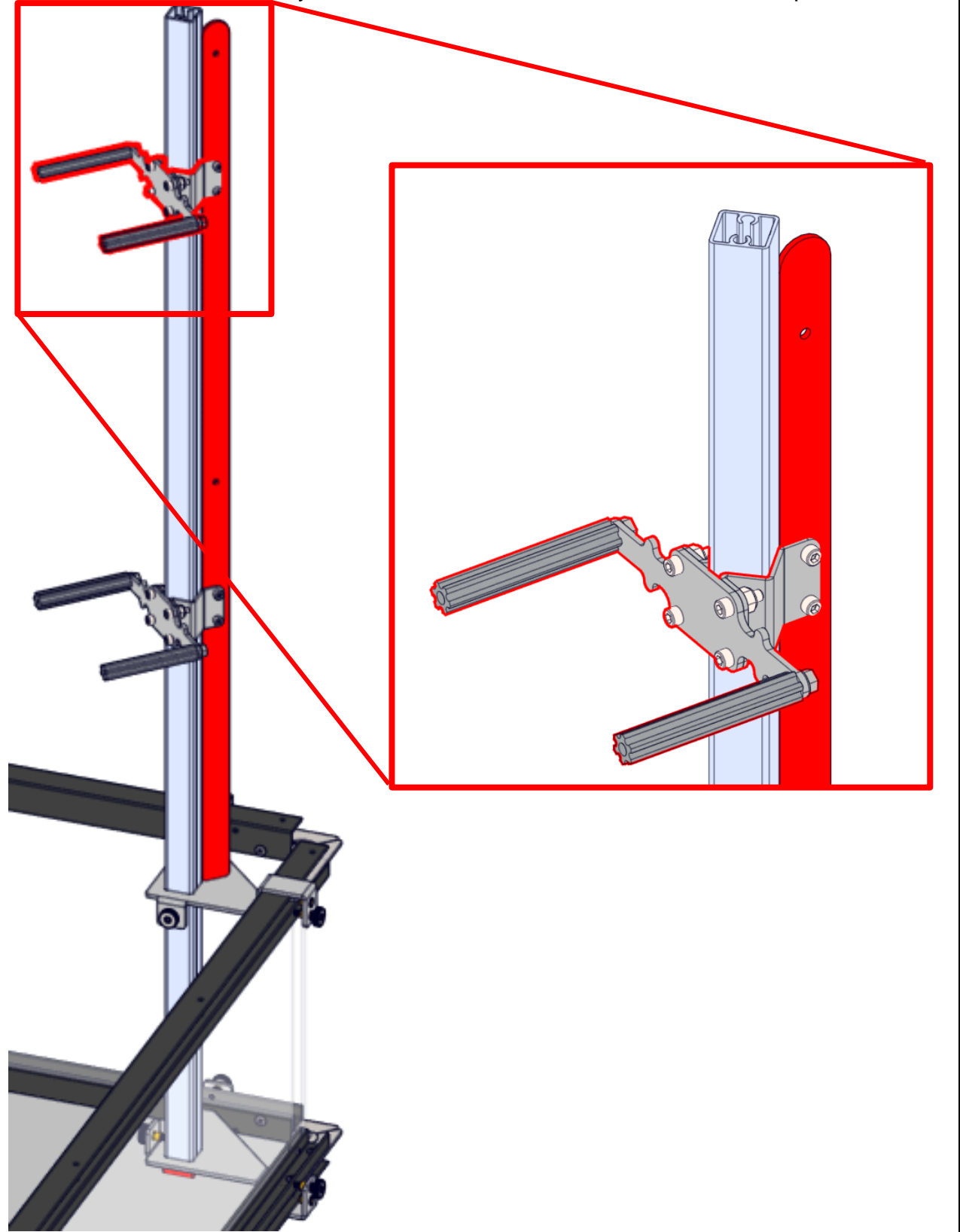

Step 10

Rest (2) Baskets (am-3015) on the Basket Mounting Assemblies. Attach the Baskets to the Basket Structure with (6) Cable Ties (am-1631 natural), as shown. Cinch the Cable Ties down completely and cut off the leftover tails. **Ensure the heads of the Cable Ties remain outside the Basket.**

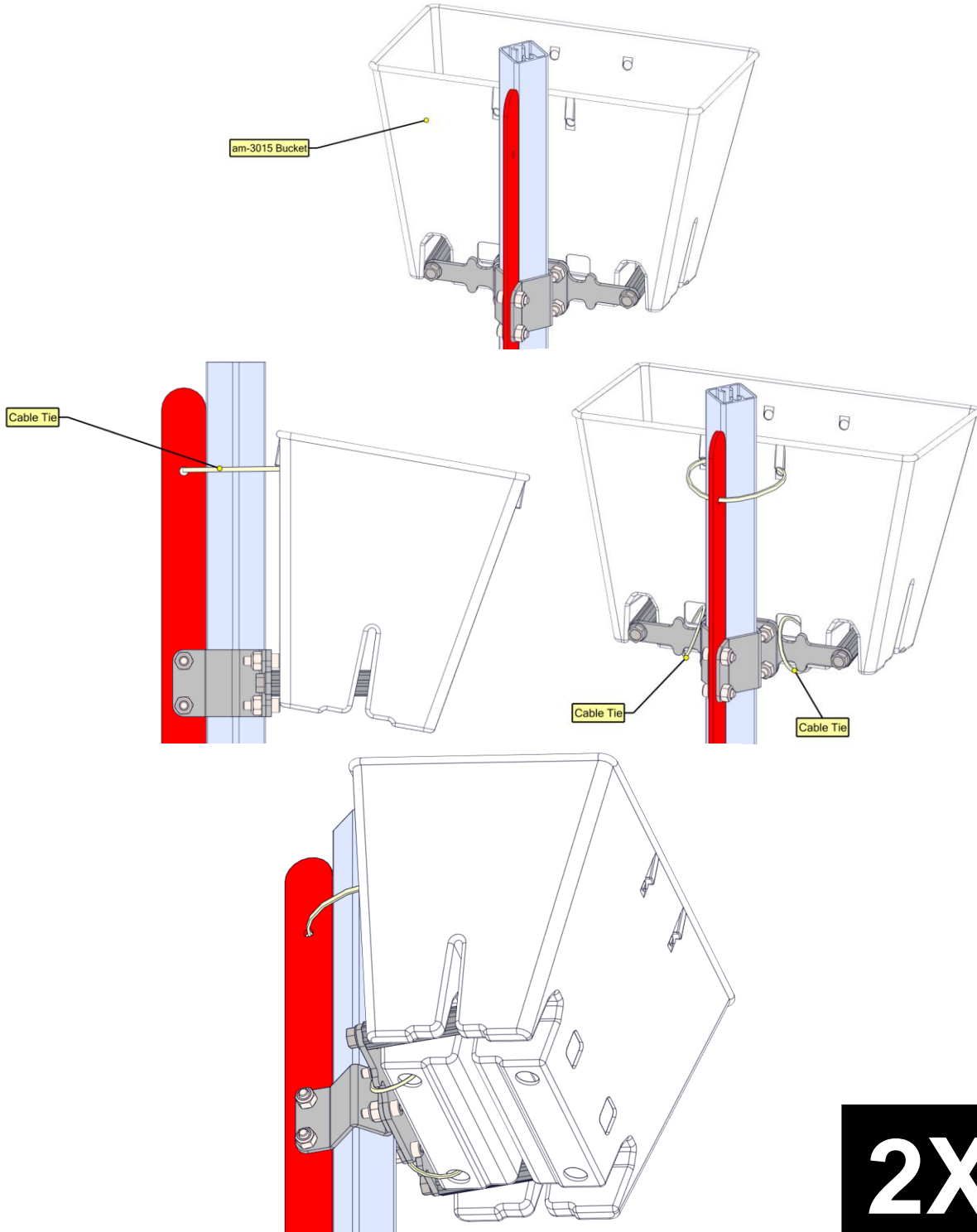

Step 11

Slide (1) Square Peanut Cap (am-4305_red if building over Tile F1, am-4305_blue if building over Tile A6) over top of the 44.5in Peanut (am-5412). The Basket Structure is now complete. If building a Full Field, repeat Steps 1 through 11 above Tile A6 or F1, whichever has not already been used.



TAPE LINES



Tape Lines

ALLIANCE AREAS

Each alliance has one Alliance Area, a 120" by 42" box placed 18" from the edge of the field border parallel with the red/blue Chambers on the Submersible and in line with the perpendicular edge as shown. The red Alliance Area uses **red tape**, the blue Alliance Area uses **blue tape**.

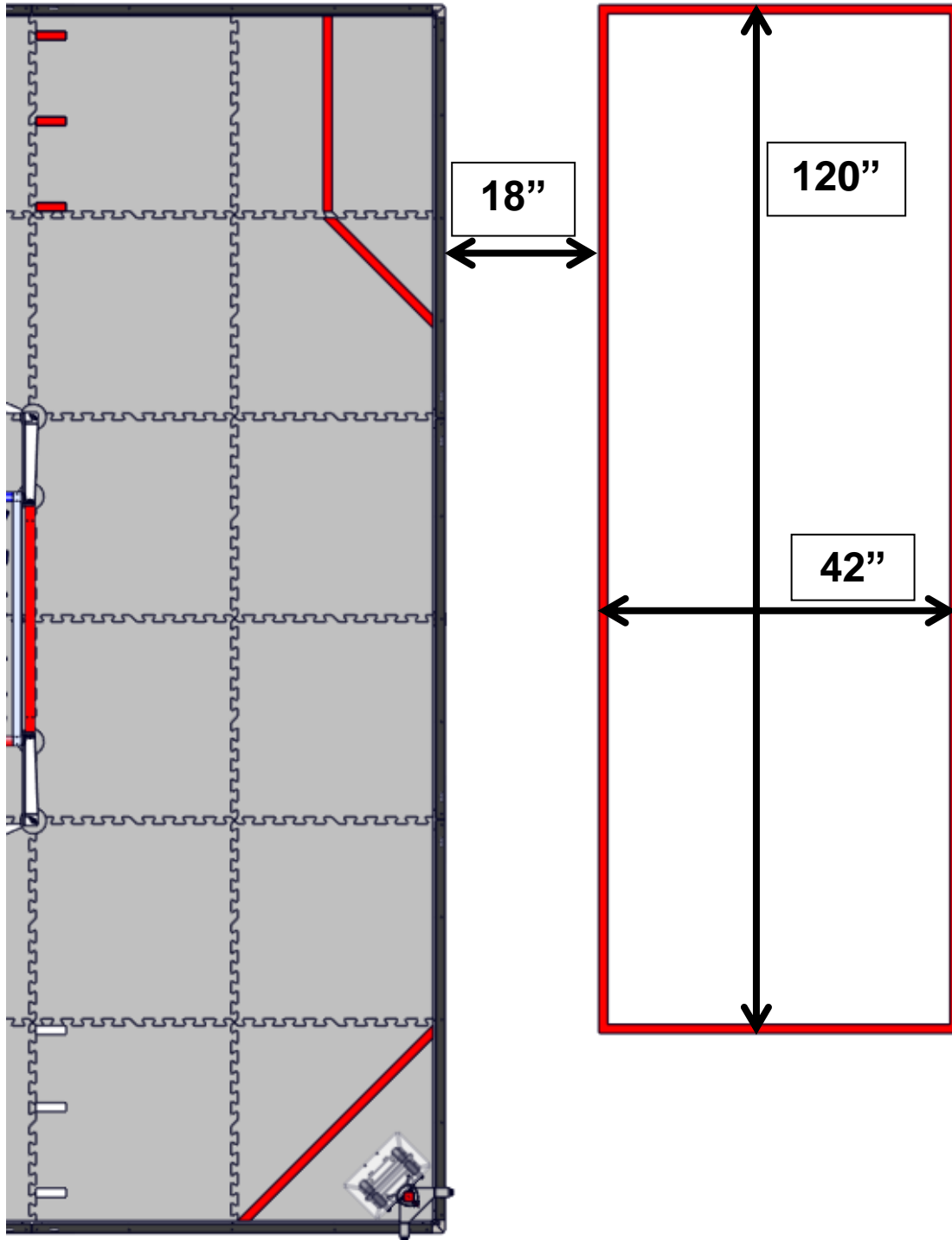

OBSERVATION ZONES

Each alliance has one Observation Zone in opposite corners of the field closest to their Chambers on the Submersible. The Observation Zone is marked using a strip of tape travelling across an entire corner tile parallel with the Chambers, 10" away from the tile edge as shown. On the next tile, another strip of tape is placed at a 45 degree angle as shown. The red Observation Zone spans tiles F5 and F6 and uses **red tape**, while the blue Observation Zone spans tiles A1 and A2 and uses **blue tape**.

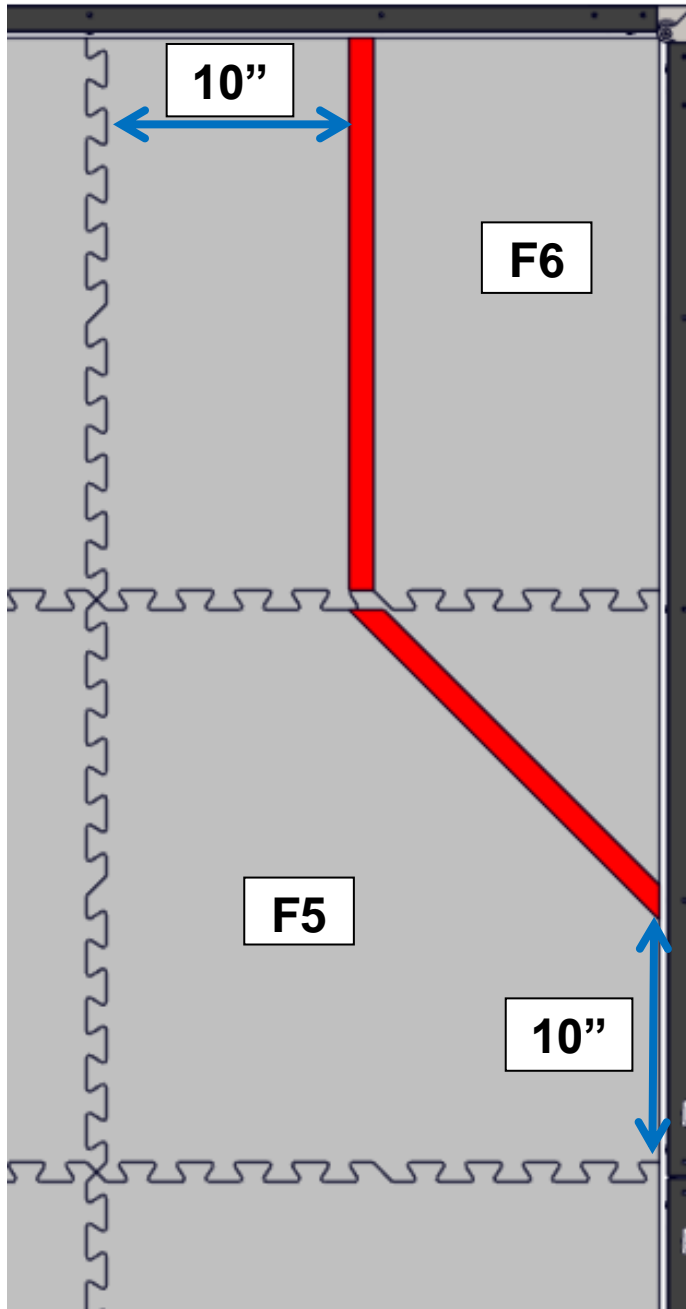

NETS

The Net is marked by a piece of tape spanning the diagonal of tiles A6 and F1. **Red tape** is used for the red Net in tile F1, and **blue tape** for the blue Net in tile A6.

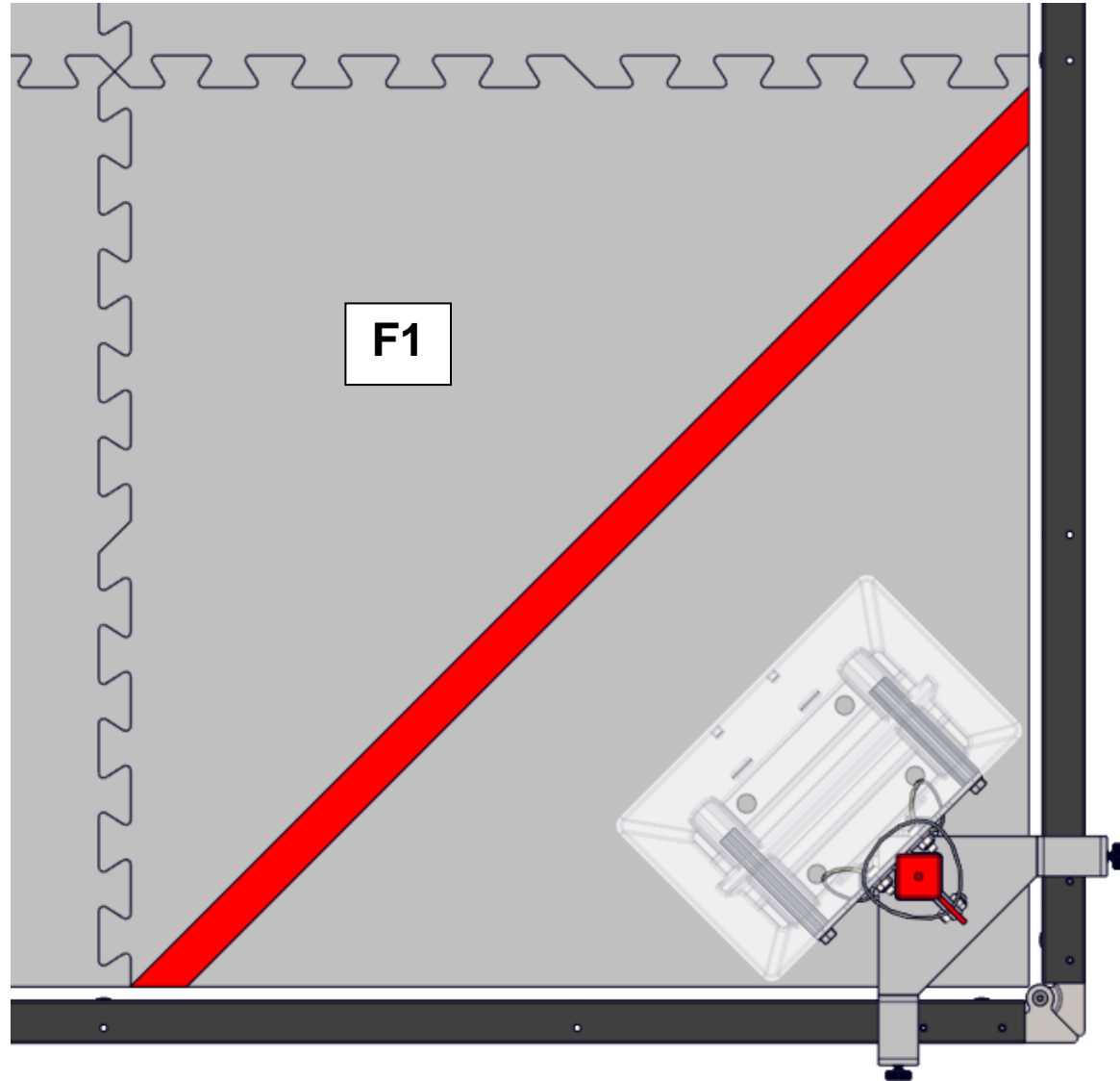

SUBMERSIBLE RUNGS

Each Submersible Rung receives three pieces of tape. Tape is wrapped around the ends of each rung and the center of each rung as shown. The top rung's tape is inset towards the center to avoid the flanges on the sheet metal that would otherwise interfere. The rungs closest to the red Baskets receive **red tape** and the rungs closest to the blue Baskets receive **blue tape**.

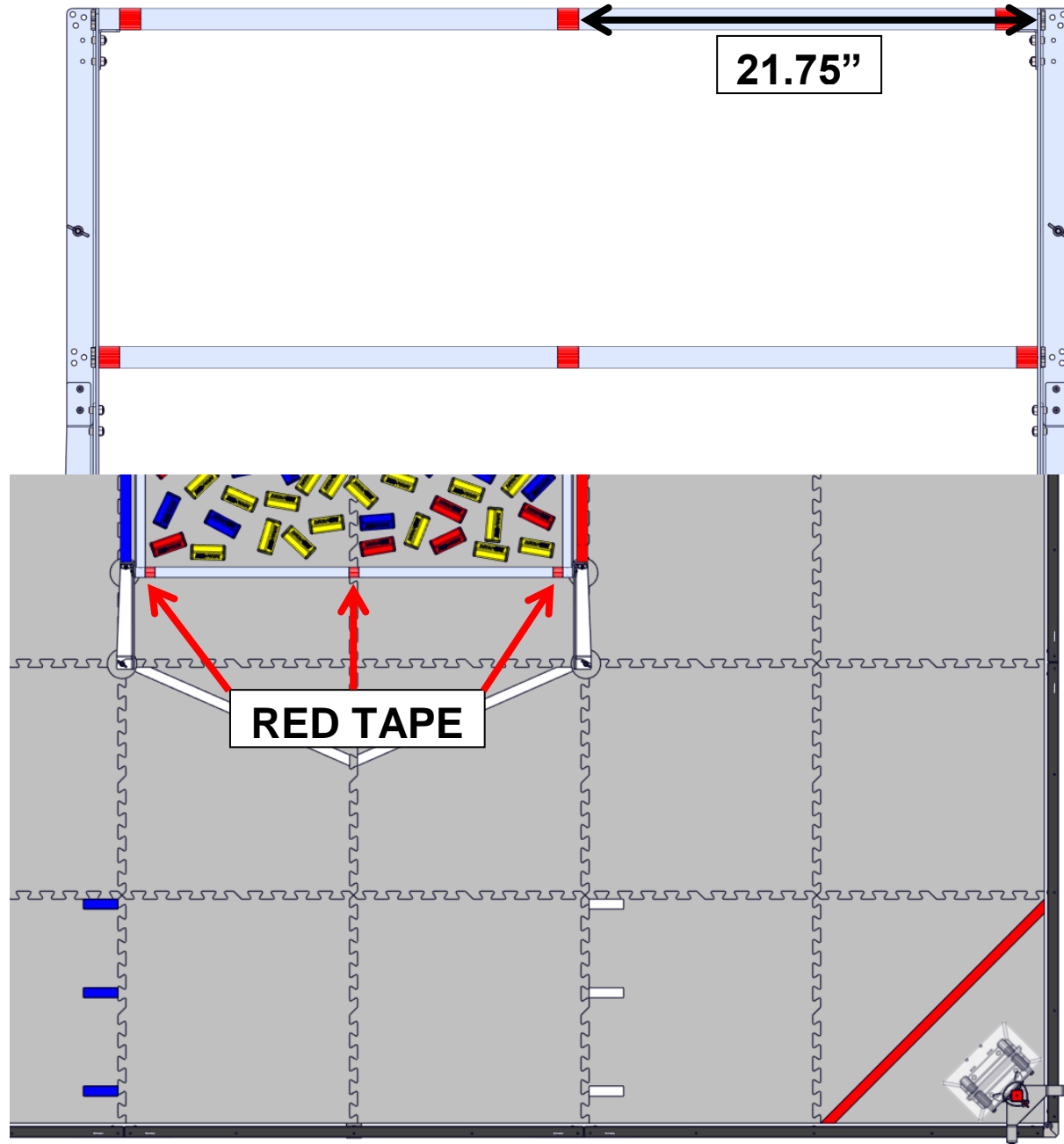

SAMPLE PRESET LINES

Adjacent to the beaches and nets, Tiles E6 (red tape), B6 (white tape), E1 (white tape), and B1 (blue tape) contain 3 sample preset lines each. Each line is 3.5" long. The first sample preset line is placed at the seam between tiles as shown at the corner closest to the Submersible. Each succeeding line is 9" further away from the closest edge of the last tape.

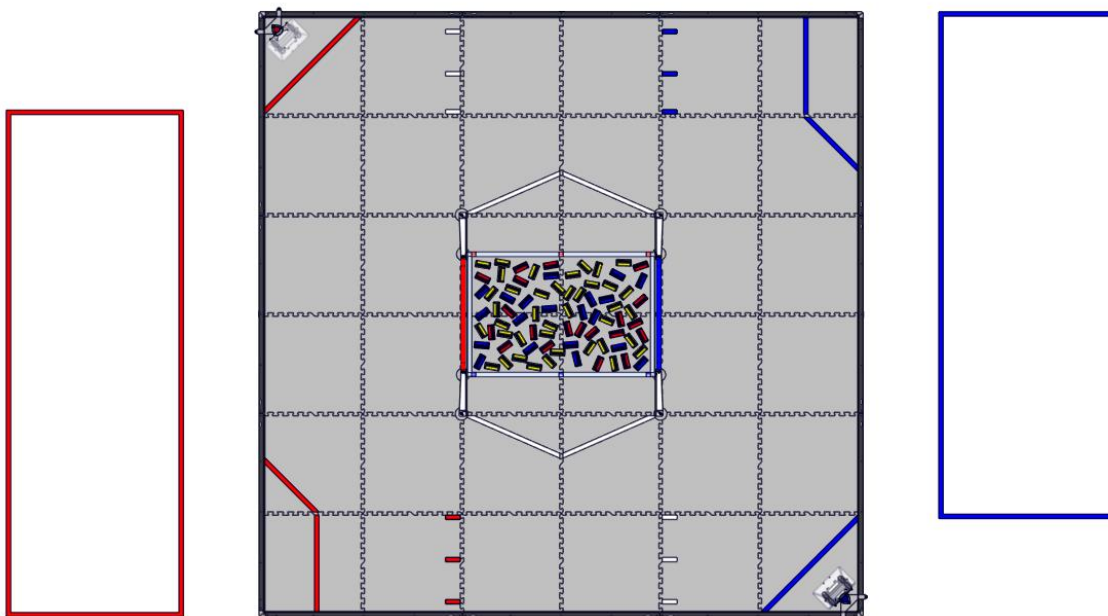
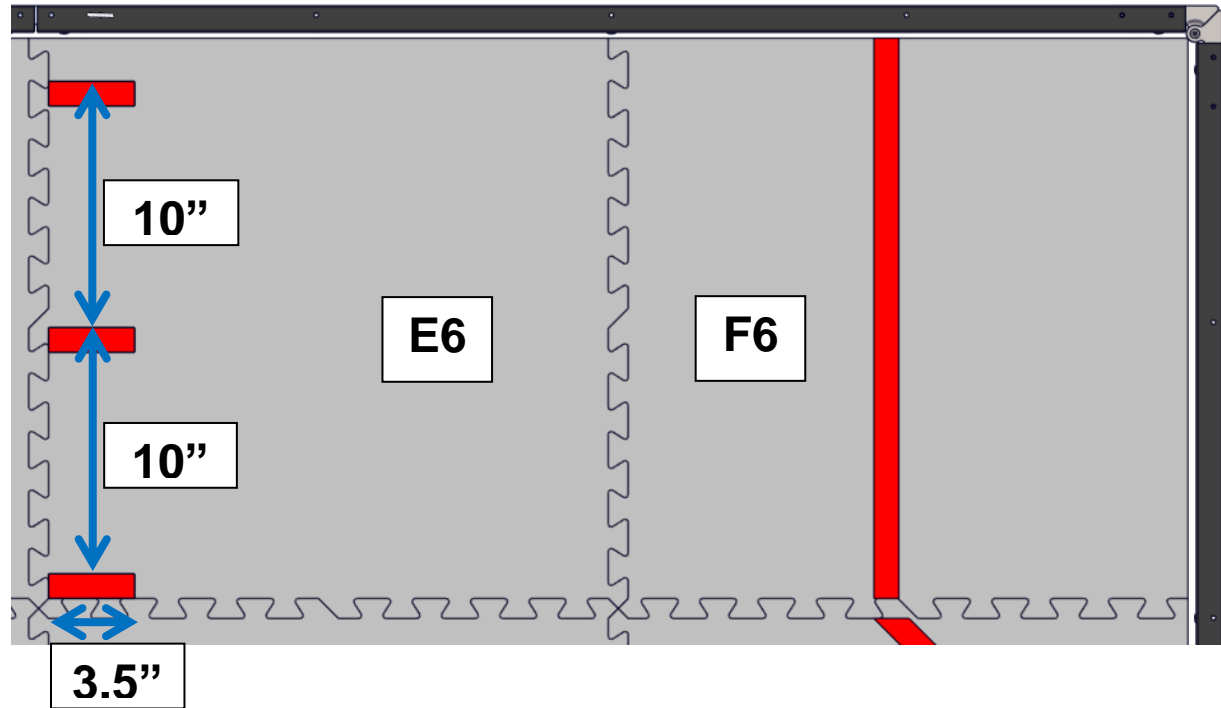

AprilTags

There are 6 AprilTags placed around the field perimeter to help aid in robot navigation. The AprilTags, found on the [Game & Season Materials Page](#), must be downloaded and printed prior to an event. Make sure to follow the printing instructions provided on the pages themselves. AprilTags should be inserted into plastic sleeves prior to placing them on the field perimeter.

Each of the 6 AprilTags provides specific instructions for where they are placed on the field and how to properly measure them to ensure they are placed at the appropriate heights. AprilTags are placed on the outside of the field perimeter to avoid any robot damage during gameplay.

A reference for their positions on the field is included below.

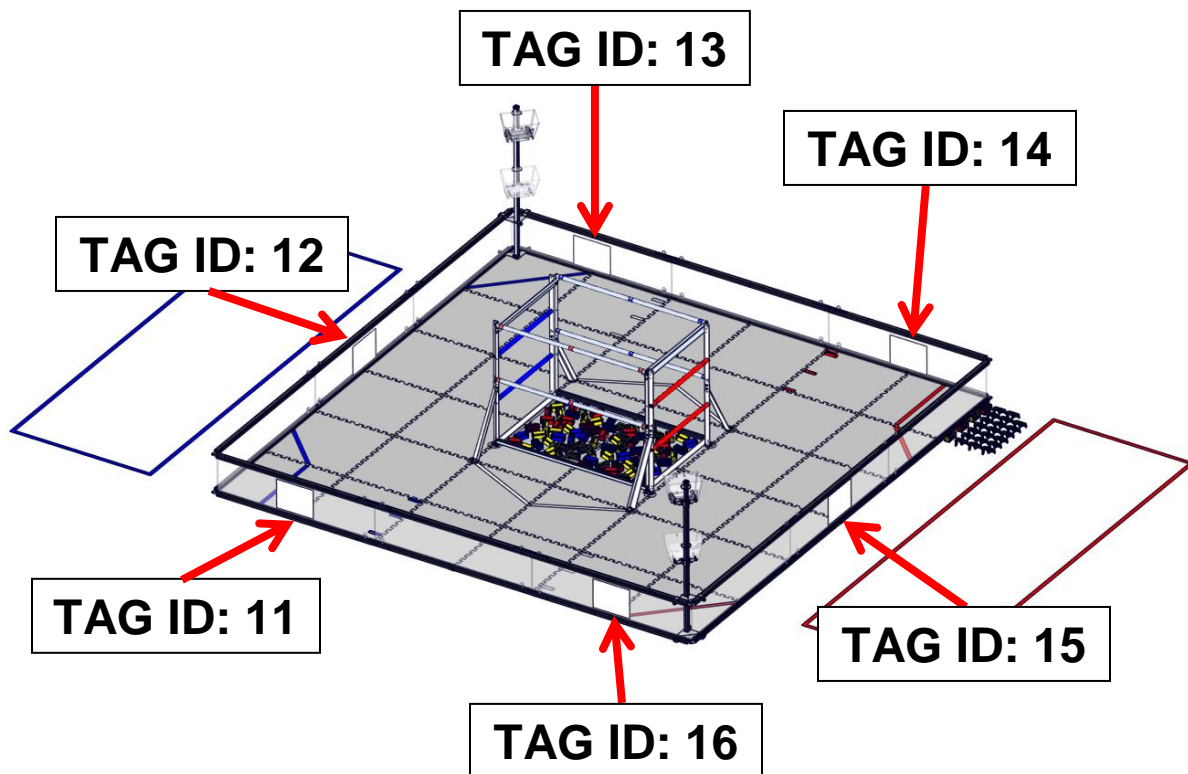

GAME-SPECIFIC TEARDOWN

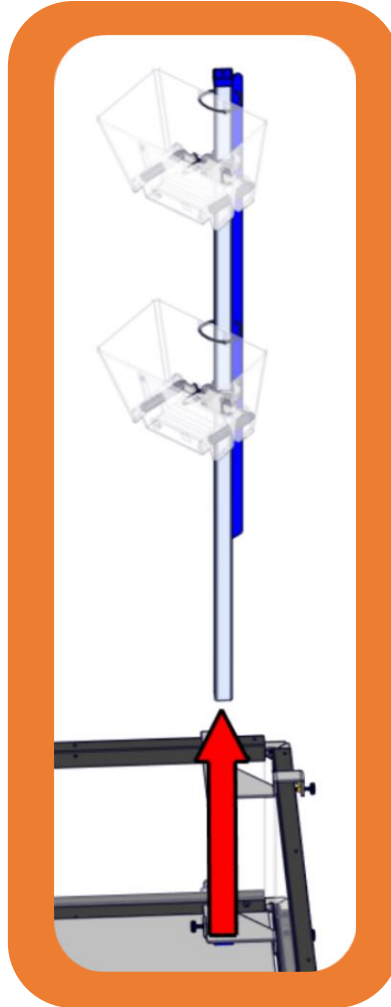

Game-Specific Teardown

Step 1

Loosen all thumbscrews and slide the 44.5" Peanut and attached components out of the Corner Brackets. Then remove the Corner Brackets and Peanut Cap from the field border.

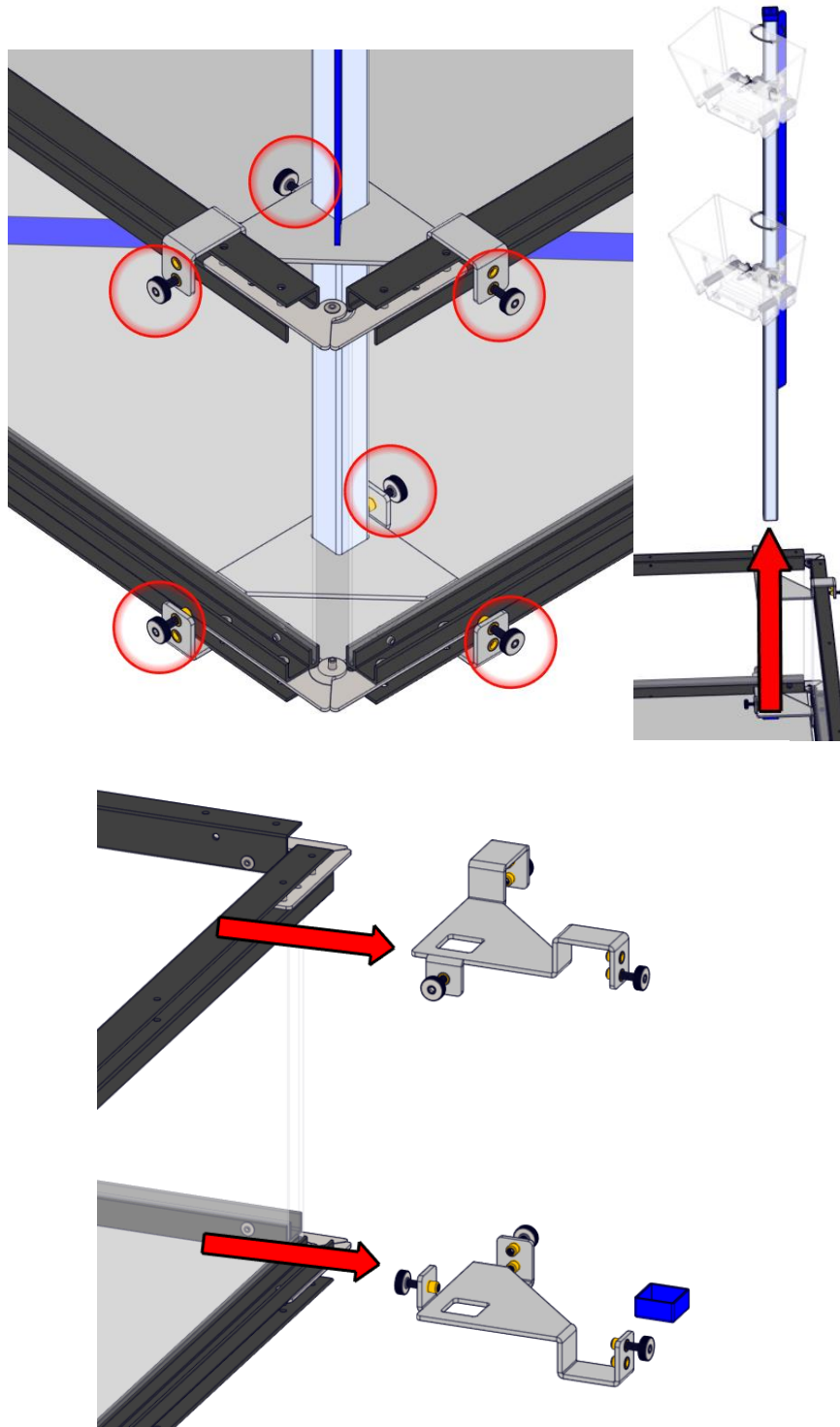

Step 2

Remove the Wing Nuts holding the Submersible to the tile and remove the Submersible assembly from the field.

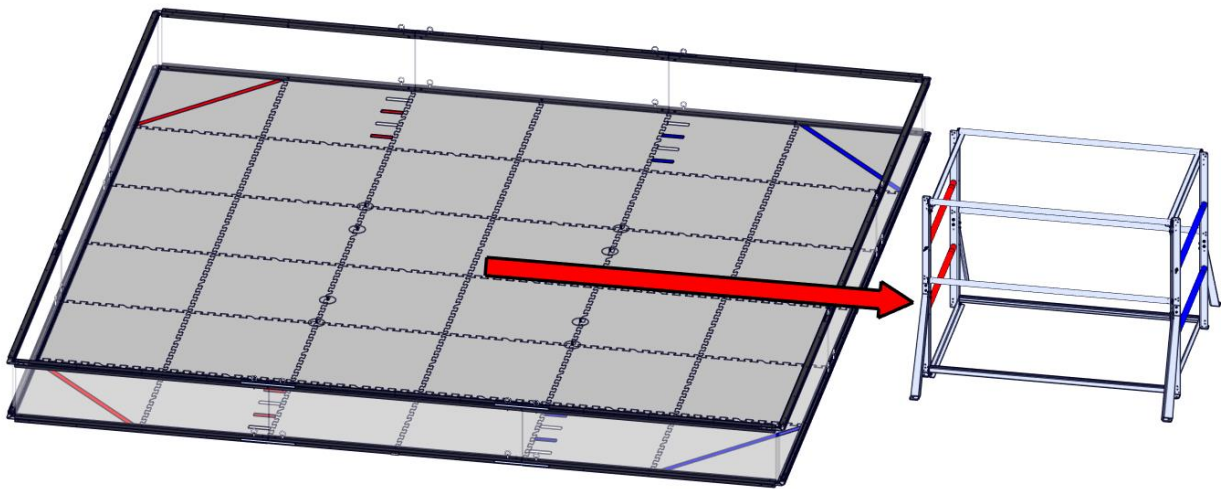
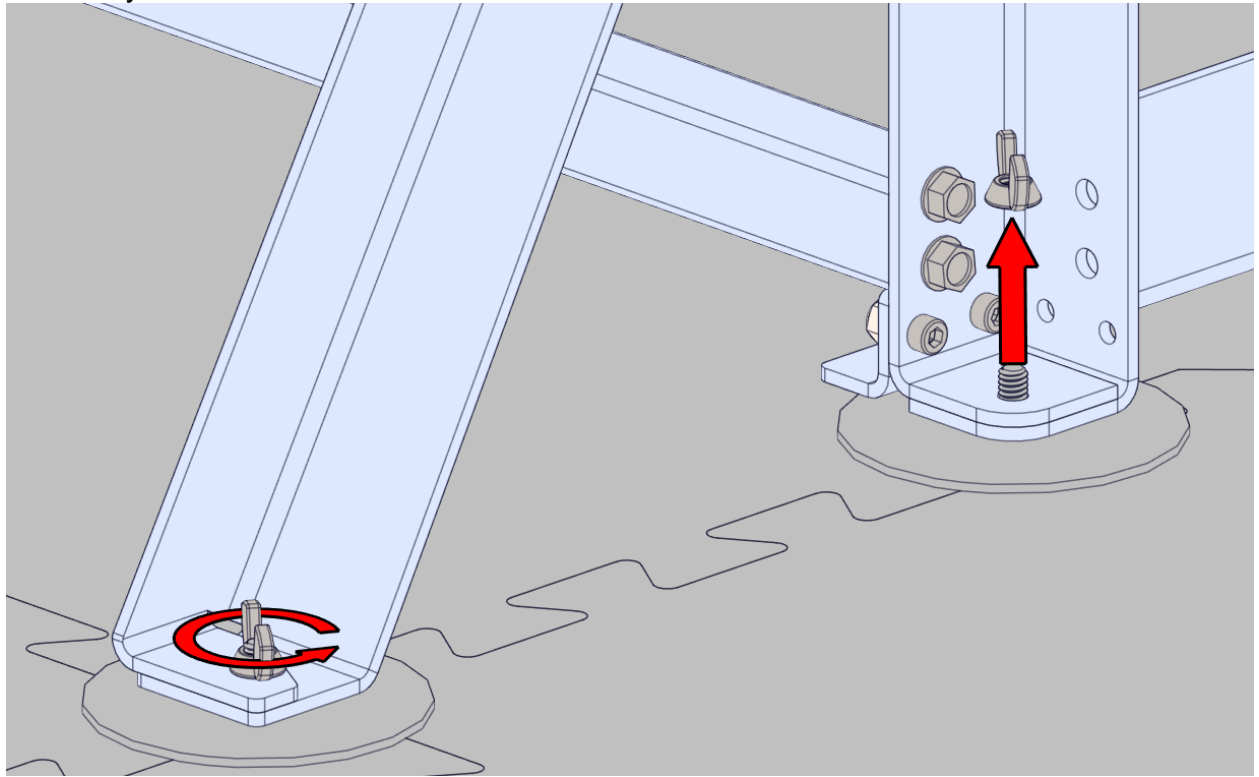

Step 3

Remove the Braces and Outriggers from the Submersible assembly by unscrewing the 10-32 Screws from the Nylock Nuts.

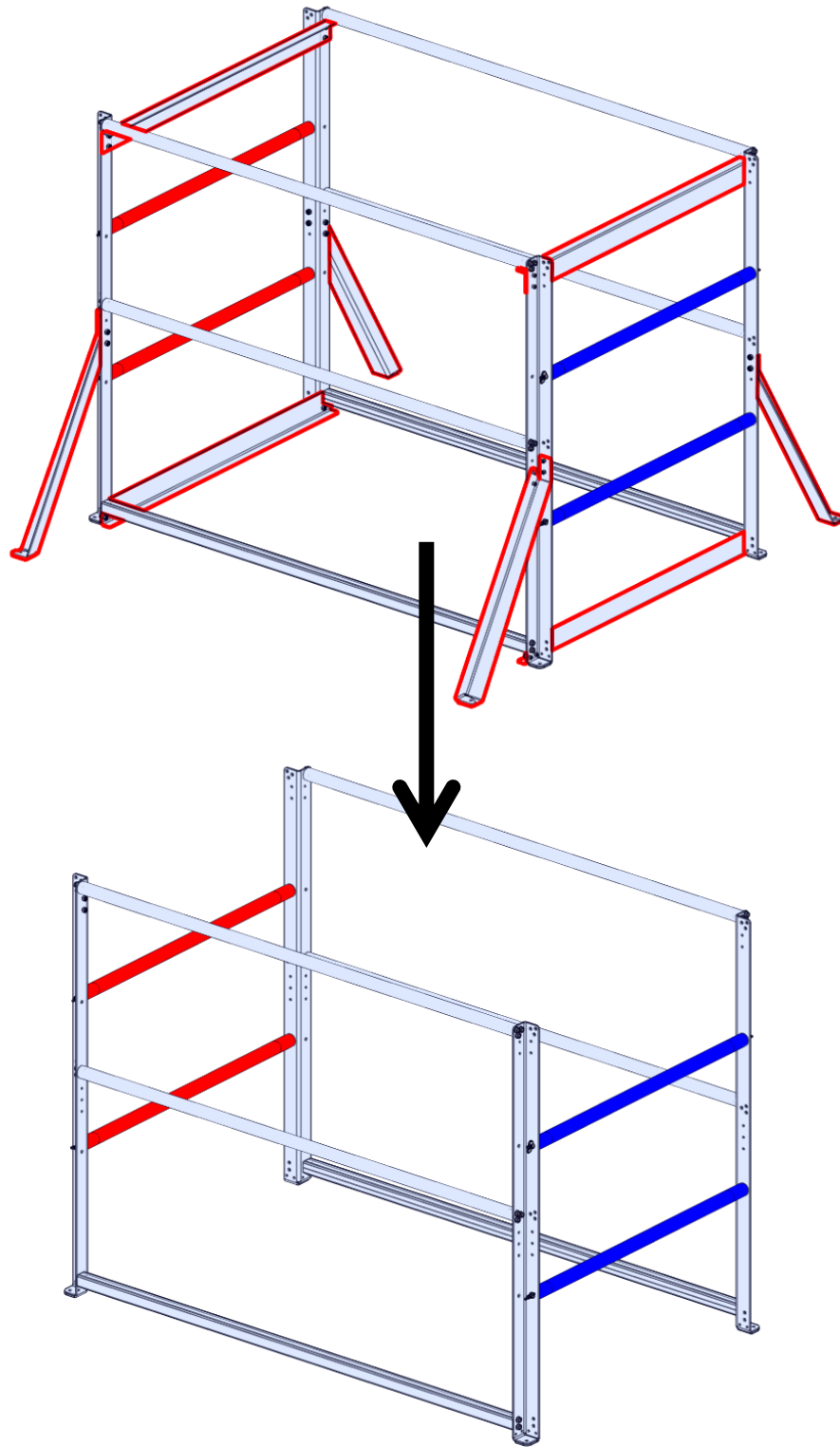

Step 4

Unscrew the Wing Nuts remaining on the Submersible and remove the red and blue scoring bars. The game-specific field elements are now disassembled for transit.

Note that the climbing rungs should NOT be removed. Repeatedly cycling the screws that hold them in could reduce the structure's stability when reassembled.

